



ZEE Systems, Inc.

COMPONENT MAINTENANCE MANUAL Z26-8900

Component

Maintenance

Manual

with

Illustrated Parts List

for

Z26-8900-(Series)

-1 / -2 / -3 / -4 / -5 / -6 / -7 / -8 / -9

MOTOR COMPRESSOR ASSEMBLY



ZEE Systems, Inc.

COMPONENT MAINTENANCE MANUAL Z26-8900

Record of Revisions

| <i>REVISION NO:</i> | <i>ISSUE DATE</i> | <i>POSTED DATE</i> | <i>INSERTED BY:</i> |
|--------------------------------|------------------------------|-------------------------------|----------------------------|
| 1 | 20 JAN 2017 | 20 JAN 2017 | ZEE Systems, Inc. |
| 2 | 28 AUG 2018 | 20 AUG 2018 | ZEE Systems, Inc. |
| 3 | 05 APR 2021 | 05 APR 2021 | ZEE Systems, Inc. |
| 4 | 12 JUN 2023 | 12 JUN 2023 | ZEE Systems, Inc. |
| | | | |
| | | | |
| | | | |
| | | | |
| | | | |
| | | | |
| | | | |



ZEE Systems, Inc.

COMPONENT MAINTENANCE MANUAL Z26-8900

**List of Effective Pages
and
Table of Contents**

| PAGE | TITLE | EFFECTIVE DATE / REV |
|-------------|---|-----------------------------|
| 1 | COVER PAGE | 4 |
| 2 | RECORD OF REVISIONS | 4 |
| 3 | LIST OF EFFECTIVE PAGES | 4 |
| 4 | . continued | 4 |
| 5 | 1.0 INTRODUCTION | 4 |
| | 1.1 THEORY OF OPERATION. | |
| | 1.2 LEADING PARTICULARS: | |
| 6 | ILLUSTRATION 1 | 4 |
| 7 | ILLUSTRATION 2 | 4 |
| 8 | ILLUSTRATION 3 | 4 |
| 9 | ILLUSTRATION 4 | 4 |
| 10 | ILLUSTRATION 5 | 4 |
| 11 | ILLUSTRATION 6 | 4 |
| 12 | 2.0 SPECIAL TOOLS AND EQUIPMENT | 4 |
| | 2.1 TOOLS | |
| 13 | 2.2 MATERIALS | 4 |
| | 3.0 REPAIR AND REPLACEMENT OF COMPONENTS. | |
| 14 | ILLUSTRATION 7 | 4 |
| | 3.1 DRIVE BELT | |
| 15 | ILLUSTRATION 8 | 4 |
| | 3.2 COMPRESSOR | |
| 16 | ILLUSTRATION 9 | 4 |
| | ILLUSTRATION 10 | |
| 17 | TABLE 1. | 4 |
| | ILLUSTRATION 11 | |
| 18 | 3.3 MOTOR, COMPRESSOR DRIVE | 4 |
| 19 | ILLUSTRATION 12 | 4 |
| | ILLUSTRATION 13 | |
| 20 | 3.4 WIRING | 4 |
| | WIRING DIAGRAM 1 | |
| 21 | WIRING DIAGRAM 2 / 3 | 4 |
| | 4.0 SERVICING – REFRIGERANT CHARGE | |
| 22 | 5.0 SERVICE SCHEDULES | 4 |
| | 5.1 MAINTENANCE SCHEDULE | |
| | 6.0 TOLERANCES | 4 |
| | 6.1 COMPRESSOR OIL | |
| | 6.2 CLUTCH | |
| | 6.3 REFRIGERANT CHARGE | |
| | 6.4 BRUSH LENGTH, COMPRESSOR DRIVE MOTOR. | |
| | 6.5 TORQUE VALUES. | |



ZEE Systems, Inc.

COMPONENT MAINTENANCE MANUAL Z26-8900

| <i>PAGE</i> | <i>TITLE</i> | <i>EFFECTIVE DATE / REV</i> |
|--------------------|--|------------------------------------|
| 23 | 7.0 TROUBLE SHOOTING | 4 |
| 24 | 8.0 ILLUSTRATED PARTS LIST | 4 |
| | 8.1 EXPLANATION OF SYMBOLS | |
| 25 | 8.2 IPL Z26-8900 MOTOR COMPRESSOR ASSY | 4 |
| 26 | . continued | 4 |
| 27 | . continued | 4 |
| 28 | . continued | 4 |
| 29 | . continued | 4 |
| 30 | FIGURE 1 | 4 |
| 31 | FIGURE 2 | 4 |
| 32 | FIGURE 3 | 4 |
| 33 | FIGURE 4 | 4 |
| 34 | FIGURE 5 | 4 |
| 35 | FIGURE 6 | 4 |
| 36 | FIGURE 7 | 4 |
| 37 | FIGURE 8 | 4 |
| 38 | 9.0 SUMMARY OF MODIFICATIONS | |
| | 10.0 REVISION SUMMARY | |

* INTITIAL RELEASE 1-28-06



ZEE Systems, Inc.

COMPONENT MAINTENANCE MANUAL Z26-8900

1.0 INTRODUCTION

1.0.1 The purpose of this manual is to provide instructions for the service, maintenance and repair of the Z14-601 Power Condenser Assembly. This manual is not intended to provide instructions to maintain the complete air conditioning system.

1.0.2 In some installations the compressor is equipped with back seating valves. Refer to the *Illustration 7* for back seat valve operation.

1.1 THEORY OF OPERATION. The Z26-8900 Motor Compressor (MC) Assembly is used in the vapor cycle air conditioning circuit to pump refrigerant through the system. The MC is made up of a drive motor, pulleys, belt, compressor and mounts. The constant speed drive motor turns the compressor through cogged pulleys and belt drive. As the compressor turns, low pressure refrigerant and the heat absorbed in the evaporator is drawn into the compressor suction port, it is compressed and pumped out as a high pressure gas to the condenser coil. The compressor RPM is determined and maintained by calculated pulley ratios. The pulley at the compressor clutch is engaged when power is applied to the coil. Safety devices in the electrical circuit will disengage the compressor clutch when under or over pressure conditions occur or, if applicable, cabin temperature conditions are met.

NOTE

Units are shipped with the back seat valve in the front seat position to prevent oil leakage during transit. Always place the valve in the proper position and replace the black seal cap prior to operation. Improper valve position could cause damage to the compressor.

1.2 LEADING PARTICULARS:

MOTOR

| | |
|---------------------------------------|--------------|
| Rating – Horsepower..... | 3.75 |
| Voltage – Direct Current..... | 26-31 |
| Load – Continuous Duty (amperes)..... | 150A |
| Speed – Under Load (RPM)..... | 7,500 |
| Motor Cooling..... | Internal Fan |
| Rotation – Viewed from Drive End..... | Clockwise |

COMPRESSOR

Coil, Clutch

| | |
|--|-----------|
| Voltage – Direct Current..... | 16-30 |
| Power Consumption – Coil Continuous..... | 34W |
| Speed – Clutch (Max Continuous RPM)..... | 6,500 |
| Rotation – Viewed from Drive End..... | Clockwise |

Hose connections at compressor

| | |
|-------------------------|--------------------|
| Discharge (SAE #8)..... | 3/4-16 Male Tube-O |
| Suction (SAE #10)..... | 7/8-14 Male Tube-O |

MOTOR – COMPRESSOR ASSY

| | |
|---|------------------------|
| Weight with oil – Assembly Net Pounds [Kg]..... | 33 [15.0] to 39 [17.7] |
| Dimensions – Inches | See <i>BELOW</i> |

The dimension illustrations are for reference only, DO NOT SCALE.



ZEE Systems, Inc.

COMPONENT MAINTENANCE MANUAL Z26-8900

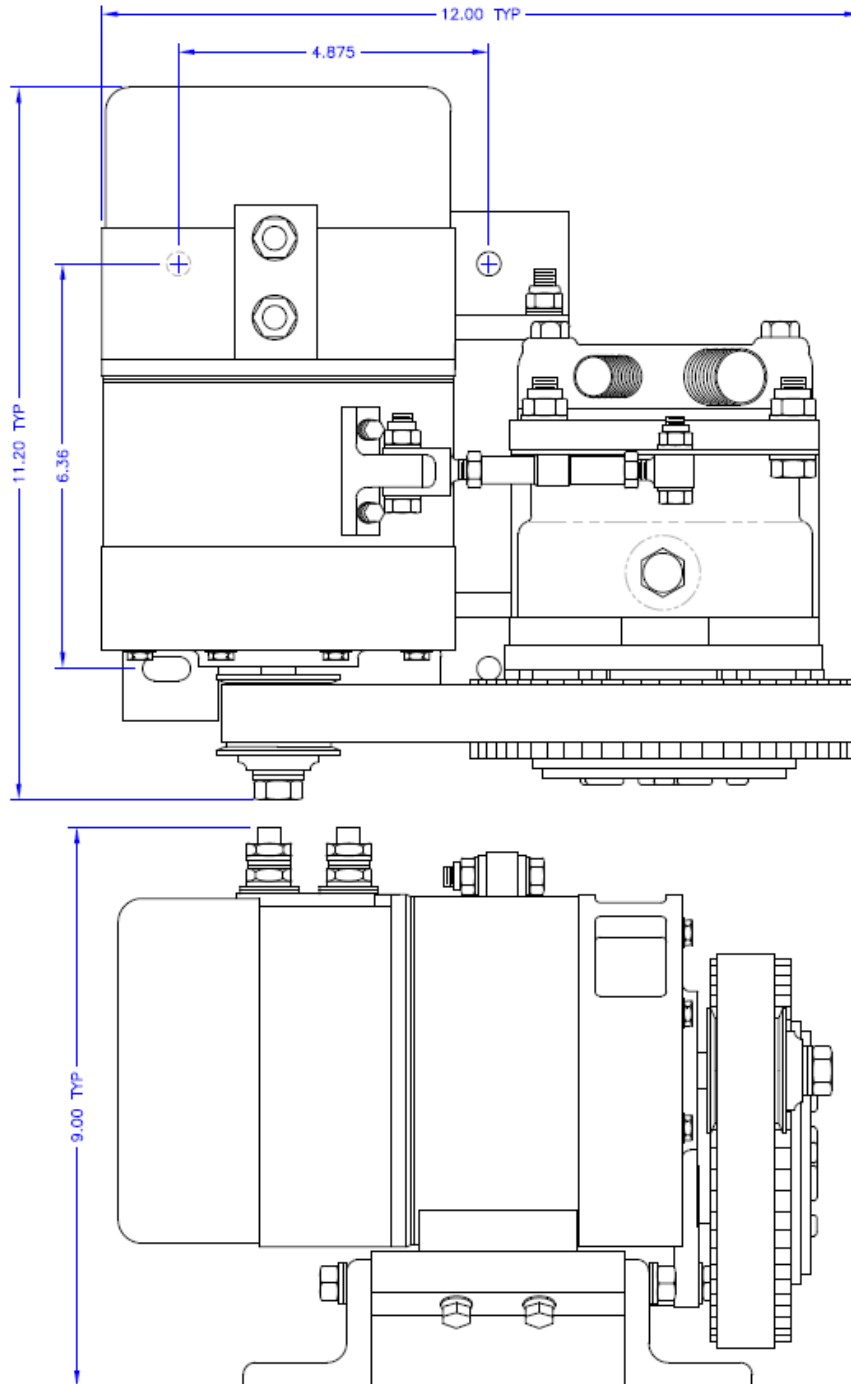

**Z26-8900-1 / -3 / -5
ILLUSTRATION 1.**



ZEE Systems, Inc.

COMPONENT MAINTENANCE MANUAL Z26-8900

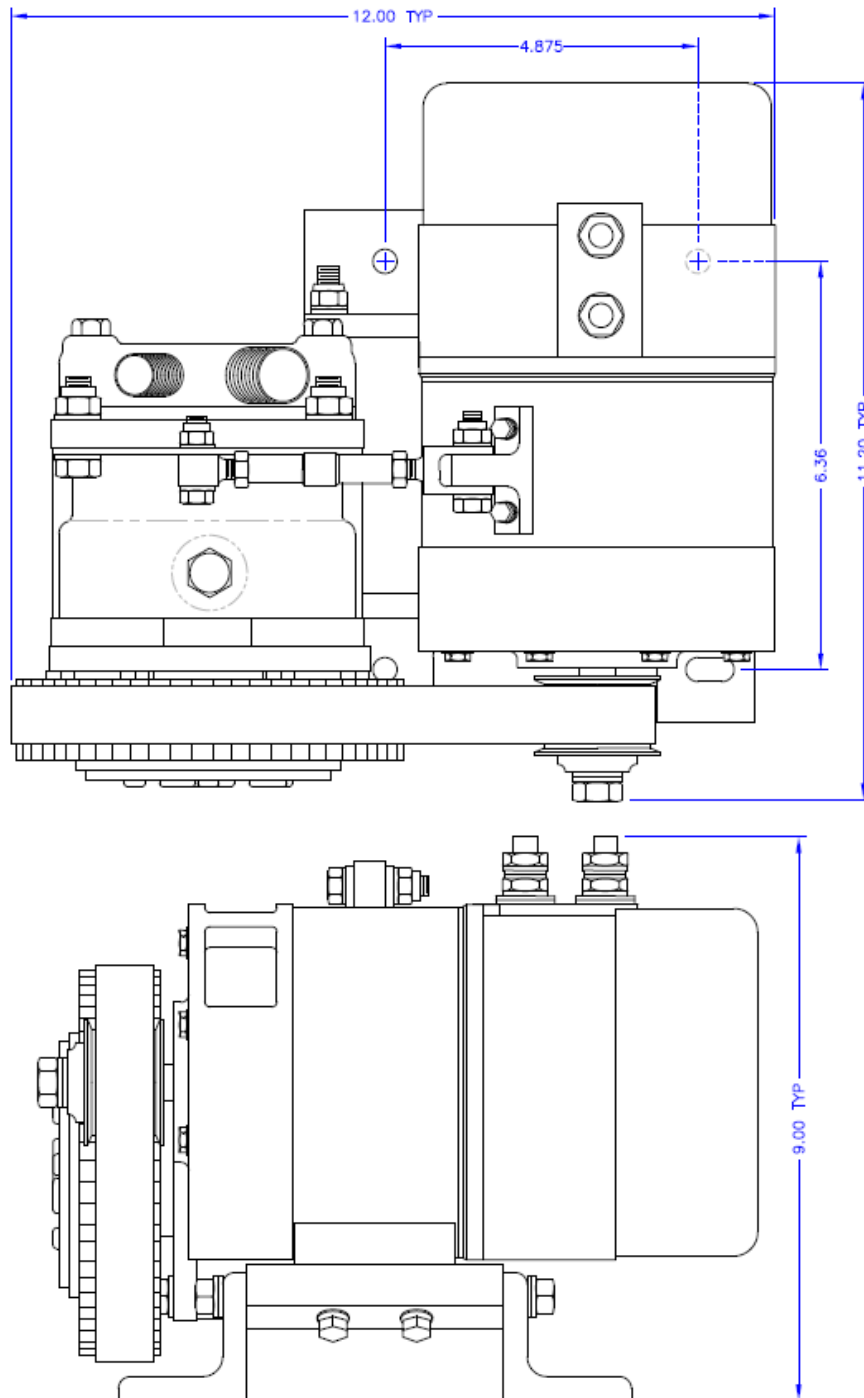

**Z26-8900-2 / -4
ILLUSTRATION 2.**



ZEE Systems, Inc.

COMPONENT MAINTENANCE MANUAL Z26-8900

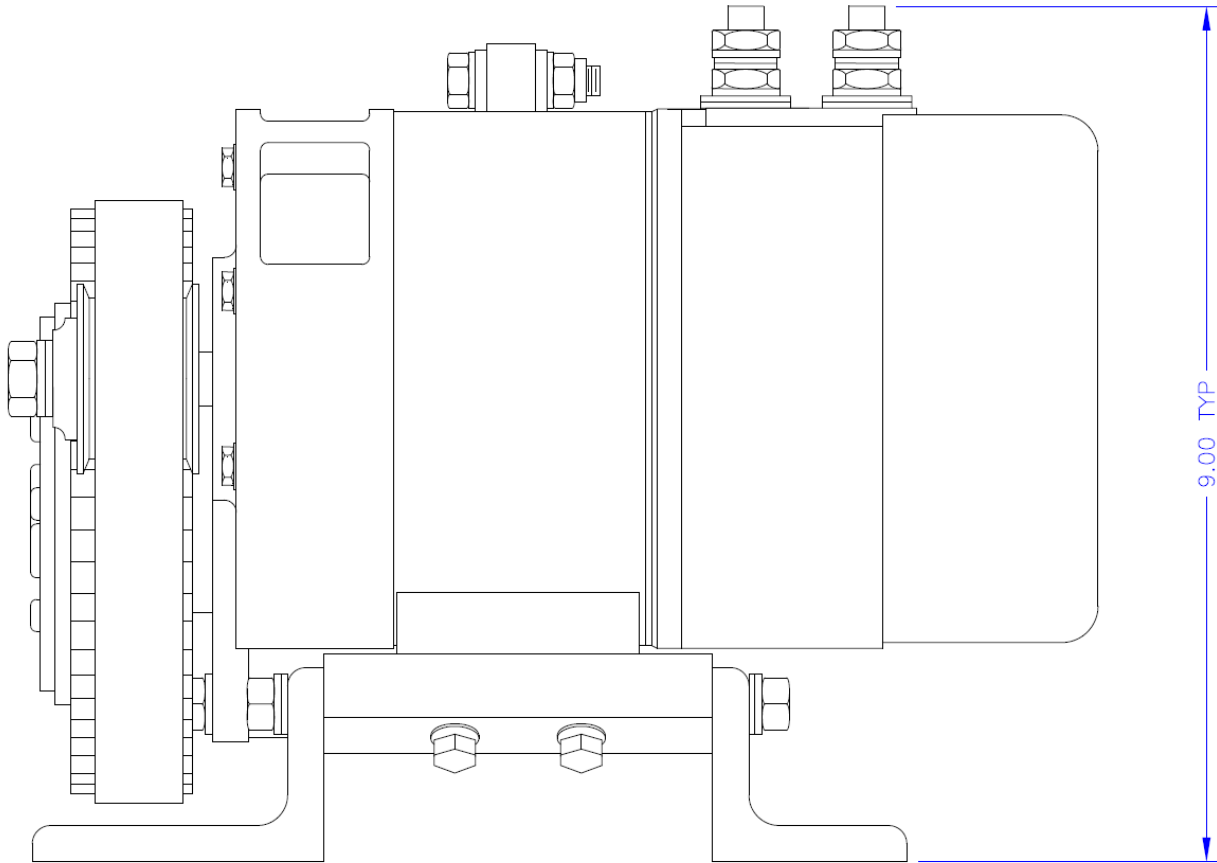

**Z26-8900-6
ILLUSTRATION 3.**



ZEE Systems, Inc.

COMPONENT MAINTENANCE MANUAL Z26-8900

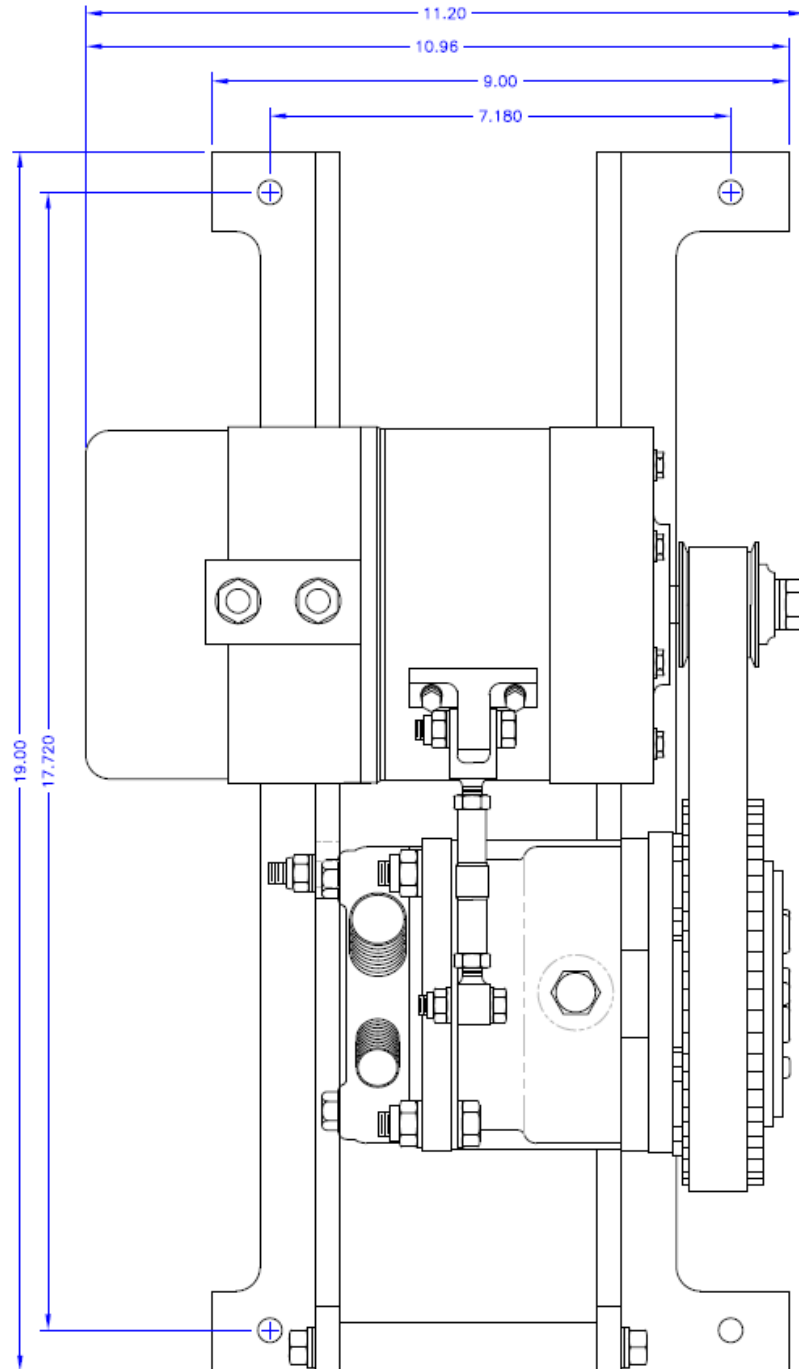

**Z26-8900-6
ILLUSTRATION 4.**



ZEE Systems, Inc.

COMPONENT MAINTENANCE MANUAL Z26-8900

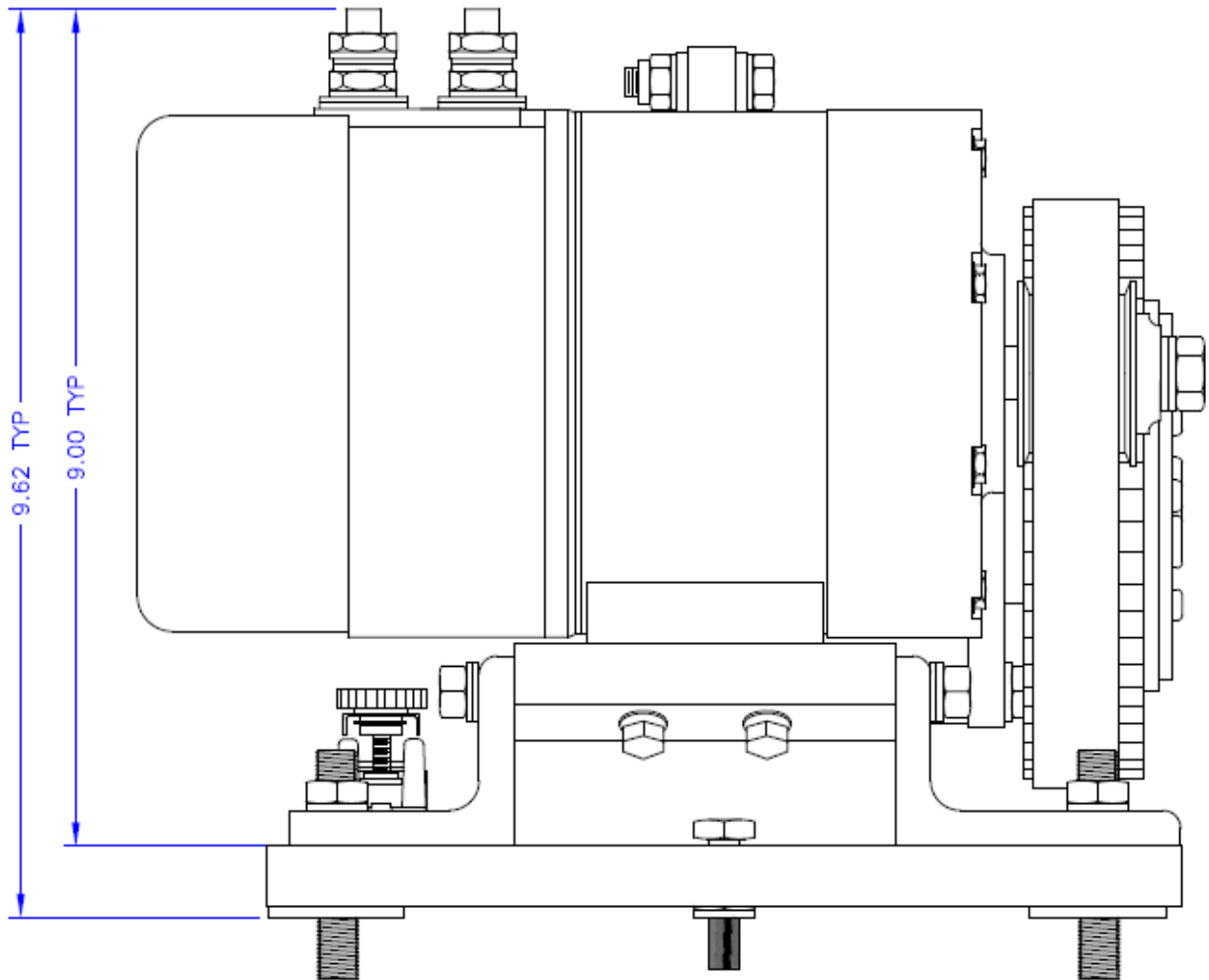

**Z26-8900-7 / -8 / -9
ILLUSTRATION 5.**



ZEE Systems, Inc.

COMPONENT MAINTENANCE MANUAL Z26-8900

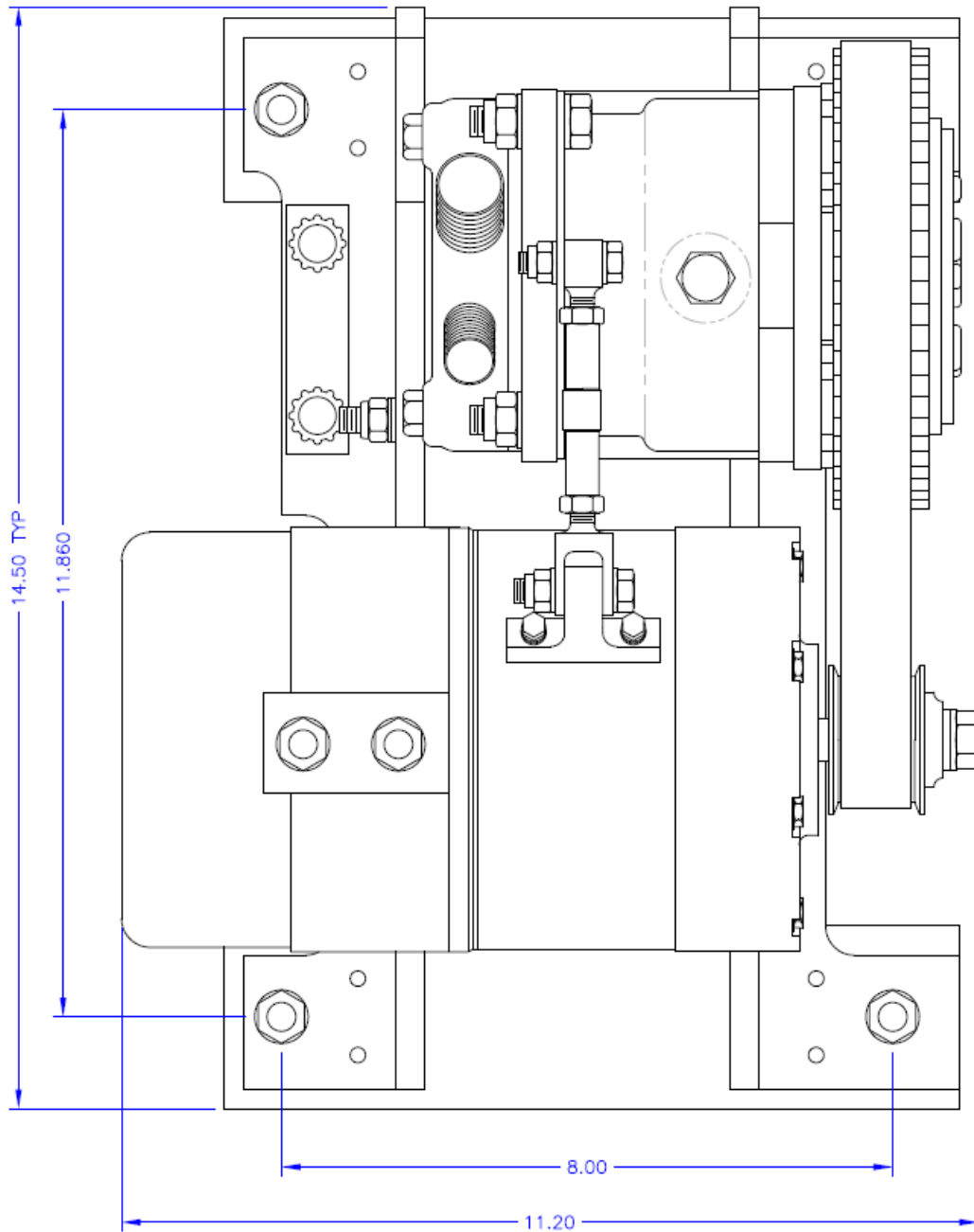

**Z26-8900-7 / -8 / -9
ILLUSTRATION 6.**



ZEE Systems, Inc.

COMPONENT MAINTENANCE MANUAL Z26-8900

2.0 SPECIAL TOOLS AND EQUIPMENT

2.1 TOOLS: The following special tools are required to perform the maintenance described in this manual.

| ITEM | SOURCE |
|---|----------------------------------|
| Dip, Stick, Compressor Oil | Refer to <i>Illustration 2</i> . |
| Belt deflection gauge. | Commercially available. |
| 14 mm socket | Commercially Available. |
| 17 mm wrenches/sockets | Commercially Available. |
| Feeler Gauges. | Commercially Available. |
| External Snap Ring Pliers. | Commercially Available. |
| External Snap Ring Pliers. | Commercially Available. |
| Spanner wrench. | Commercially Available. |
| Graduated Cylinder. | Commercially Available. |
| Leak Detector, for HFC-134a * | Commercially Available. |
| Power Supply capable of 28VDC, 50 Amps | Commercially Available. |
| Refrigerant Recovery/Recycle equipment * meeting SAE J1990 or J2209 specifications. | Commercially Available. |
| Manifold Gauge Set, R-134a, with * automotive service connections. | Commercially Available. |
| Refrigeration Vacuum Pump. * | Commercially Available. |
| Scale with 0.1 lb. increments (minimum). * | Commercially Available. |

* This equipment is used to remove refrigerant and to test and service the air conditioning system. It is listed or reference only.

2.1.2 Refer to applicable ZEE SYSTEMS Service Letter(s) for any additional special tools which may be required to service the air conditioning system.



ZEE Systems, Inc.

COMPONENT MAINTENANCE MANUAL Z26-8900

2.2 MATERIALS: The following material may be required to perform maintenance described in this manual.

| ITEM | SOURCE |
|-----------------------|-------------------------|
| MS20995C25 Lock Wire | Commercially Available. |
| Refrigerant, HFC-134a | Commercially Available. |

NOTE

***When servicing the air conditioning system always use virgin refrigerant.
DO NOT use recovered refrigerant.***

| | |
|---|-------------------------|
| PAG Lubricant, Refrigeration (HFC-134a) | Commercially Available. |
| Sanden SP-20 (PAG) or equivalent | Commercially Available |
| MOPAR 82300349 (PAG) | Commercially Available |
| PAG-100 | Commercially Available |

NOTE

PAG oil absorbs atmospheric moisture very quickly. Never leave the compressor or oil container exposed to air for prolonged time. Tightly reseal the oil container and compressor immediately after exposing the oil to air.

| | |
|---------------------------------|-------------------------|
| Liquid Detergent, water soluble | Commercially available. |
| Cloth, lint free | Commercially available. |
| Tape, Insulation, | Commercially available. |

3.0 REPAIR AND REPLACEMENT OF COMPONENTS. It may be necessary to remove the Z26-8900 Motor Compressor (MC) Assembly from the aircraft to perform the inspections or maintenance described in this manual. Refer to appropriate aircraft maintenance manual for removal and installation instructions.

CAUTION

AIR CONDITIONING SYSTEM UNDER PRESSURE. APPROPRIATE SAFETY MEASURES SHOULD BE TAKEN WHEN SERVICING THIS EQUIPMENT. ONLY TRAINED PERSONNEL WITH APPROVED SAFETY EQUIPMENT SHOULD PERFORM SERVICING DUTIES.

NOTE

It is unlawful to release any refrigerants to the atmosphere. Use approved recovery/recycle equipment to capture refrigerants. Use only lawful means to dispose of recovered refrigerants. Check with local agencies for approved disposal procedures.

NOTE

Cap all open lines to prevent contaminants and moisture from entering the system.



ZEE Systems, Inc.

COMPONENT MAINTENANCE MANUAL Z26-8900

NOTE

Due to the tight fit of the motor compressor condenser assembly it may be necessary to remove the motor compressor condenser assembly and the evaporator to perform some of the maintenance described below.

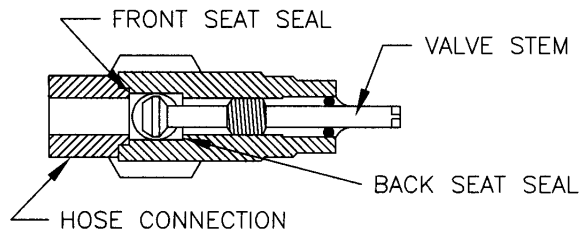

TURN VALVE STEM ALL THE WAY IN (CLOCKWISE) TO SHUT OFF CONNECTING LINE. THIS IS "FRONT SEATING". THIS ISOLATES THE REFRIGERANT FROM THE COMPRESSOR.
TURN VALVE STEM ALL THE WAY OUT (COUNTER-CLOCKWISE) FOR NORMAL OPERATION. THIS IS "BACK SEATING". THIS ALLOWS FULL FLOW THROUGH THE VALVE.

ILLUSTRATION 7.

3.1 DRIVE BELT (3-20/-21) It may be necessary to remove the Z26-8900 Motor Compressor (MC) Assembly from the aircraft to change or adjust the belt.

3.1.1 REMOVAL. Extreme care should be taken during maintenance not to strike or use pullers directly against the hardened (black or grey) area of these pulleys as this may crack or chip the anodized surface. To remove the belt break the lock wire on the turnbuckle (1-15/-34) and back off the jam nuts (1-40/-41). The groove on the turnbuckle indicates the end with the left hand thread. Loosen the hardware (1-19/-32/-38) on the clevis (1-7) that attaches to the bracket on the motor and the rod end hardware (1-6/-26/-32/-38) that attaches to the compressor. Loosen the 17 mm nut (2-43) on the 10 mm bolt (2-44) that secures the compressor to the angles (3-11/-12). You will need two 17 mm wrenching tools. Loosen the belt tension by turning the turnbuckle to bring the pulleys closer together. When the belt is loose slide it off of the large compressor pulley (2-18) then the small motor pulley (1-4/-4).

3.1.2 INSPECTION: Inspect the belt for deterioration, damage and fraying. Replace defective belt.

3.1.4 INSTALLATION: Always place the belt over the smaller diameter pulley first then carefully slide the belt over the larger diameter pulley. Care should be taken to not tear the edges of the belts.

3.1.5 BELT ADJUSTMENT: With the belt in place turn the turnbuckle (1-15/-34) until a tension with a .12-.18 deflection of the belt midway between pulleys with 3-4 pound pull is achieved. Tighten the 17 mm nut (2-43) that secures the compressor bolt (2-44) to torque of 30 foot-pounds. Secure the jam nuts (1-40/-41) and secure with lock wire. Tighten the hardware that attaches the clevis (1-29/-32/38) to the motor and rod end (1-26/-32/38) to the compressor bracket.

3.1.6 Check the belt alignment before running the motor. Turn the compressor pulley by hand to see that the belt is properly aligned. Slight striking of the belt against the rim on the small pulleys is normal but not to the point where chafing occurs. Readjust belt if necessary. Next run the motor and check for smooth operation. If a belt hops or flutters it is too loose. If the belt is too tight against the pulley rim a discharge of fine dust like rubber particles will occur. Check the condition of the smaller pulley rim and readjust belts as necessary.



ZEE Systems, Inc.

COMPONENT MAINTENANCE MANUAL Z26-8900

Secure the turnbuckle jam nuts with .025 lock wire. Once the belts are adjusted and all of the hardware is properly tightened no further adjustments should be necessary if the components are not disturbed.

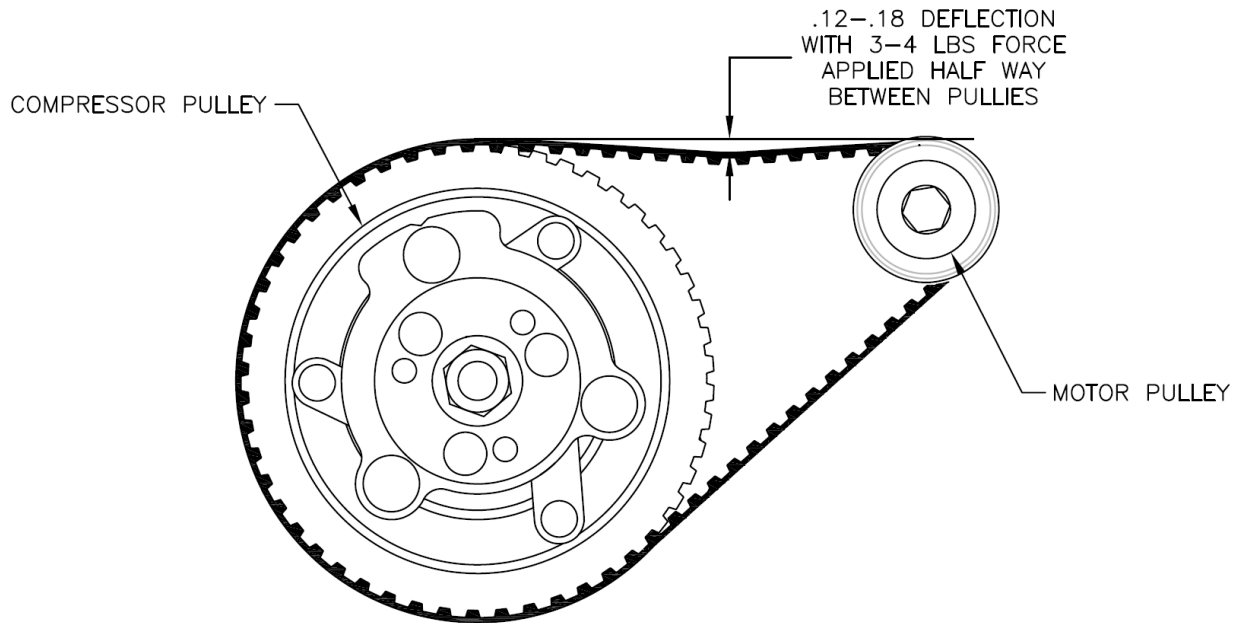

ILLUSTRATION 8.

3.2 COMPRESSOR (2-19) It is necessary to remove the compressor pulley (2-18/80) to remove the compressor from the mounting angles. Take care not to damage or lose the shims and key on the compressor shaft.

3.2.1 REMOVAL: If the system has back seat valves move the valve stem to the front seat position to isolate the refrigerant from the compressor then remove the back seat valves from the compressor.

3.2.1.1 Disconnect the electrical connections to the terminal block or motor for the clutch.

3.2.1.2 Remove the belt as described in 3.1. Remove the bolt that secures the rod end on the turnbuckle.

3.2.1.3 Hold the compressor pulley stationary while removing the 14 mm (1-23/87) retaining nut. Remove the internal snap ring (8-82B,7-16B) just under the nut. Now you can slide the clutch plate (7-16,8-82) out. Now slide the pulley (7-18,8-80) off the compressor. Take care not to damage or lose the key (8-79A, 7-19A) or shims (7-16A, 8--82A).

3.2.1.4 Loosen and remove the 17 mm (2-42) nut that secures the 10 mm bolt (2-44). Remove the 10 mm bolt and spacers (2-9/-10). The compressor can now be removed from the angles.

3.2.2 INSPECTION: Check for signs oil leakage around the fittings.



ZEE Systems, Inc.

COMPONENT MAINTENANCE MANUAL Z26-8900

3.2.2.1 Check oil level of new system installation. Fashion an oil dipstick from any soft metal bar as shown in *Illustration 3*. Determine the angle of the compressor from horizontal as shown in *Illustration 4*. Remove the oil fill plug on top of the compressor, take care not to damage the seal. Place the dipstick in the opening; make sure the dip stick goes in past the crankshaft and pistons. Refer to TABLE 1. for correct oil level and add oil as necessary. Return and tighten oil fill plug.

3.2.2.2 Check oil level of existing system. If you are replacing a failed compressor from an existing installation drain the oil from the defective compressor and record the amount. Drain the oil from the new replacement compressor. Add back the same amount of oil to the new replacement compressor that was removed from the defective compressor.

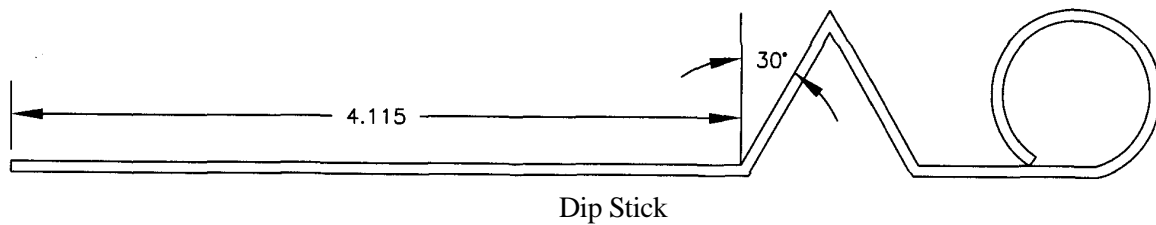
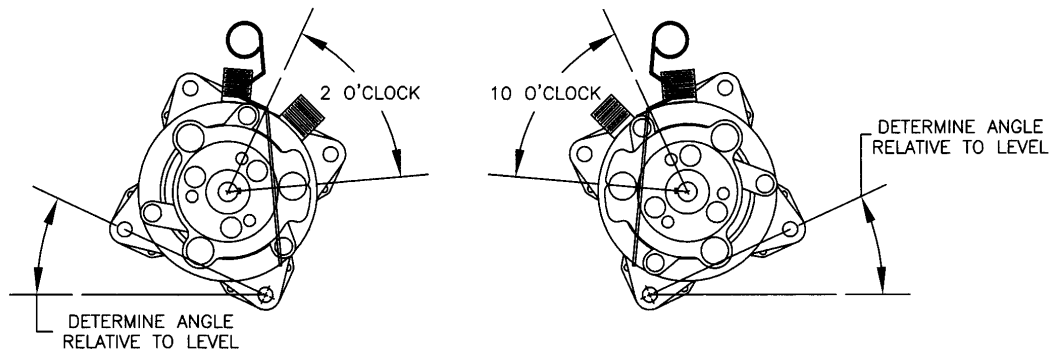

ILLUSTRATION 9.



Determine the angle of the compressor relative to horizontal.

ILLUSTRATION 10.



ZEE Systems, Inc.

COMPONENT MAINTENANCE MANUAL Z26-8900

| ANGLE | ACCEPTABLE OIL LEVEL | |
|-------|----------------------|-----------|
| | mm | INCHES |
| 0 | 9 - 15 | .35 - .59 |
| 10 | 12 - 18 | .47 - .71 |
| 20 | 15 - 21 | .59 - .83 |
| 30 | 18 - 24 | .71 - .94 |

TABLE 1.

3.2.5 INSTALLATION: With the compressor pulley removed, align the compressor and spacers (2-9/-10) with angles (3-11/-12) and slide the 10 mm x 150 mm bolt (2-44) into position. Do not forget the flat washer (2-42) under bolt head before inserting. Make sure the bolt head is on the pulley side. Tighten the 17 mm nut just enough to secure the compressor but loose enough to adjust the belt.

3.2.5.1 Slide the compressor pulley (2/7-18, 2/8-80) assembly on the compressor.

3.2.5.2 Align the key way and place the clutch plate (7-16, 8-82) on the compressor shaft. Install the internal snap ring (7-16B,8-82B). Replace the 14 mm (7-23,8-87) retaining nut and torque to 11-15 lb-ft (15-21 N-m)

3.2.5.3 Check the air gap between the clutch plate and the pulley with the feeler gauge that a clearance of .016" - .031" (0.4 – 0.8mm). If the gap is not even around the clutch, gently tap down at the high spots. If the overall air gap is out of specification remove the clutch plate and add or subtract shims as necessary.

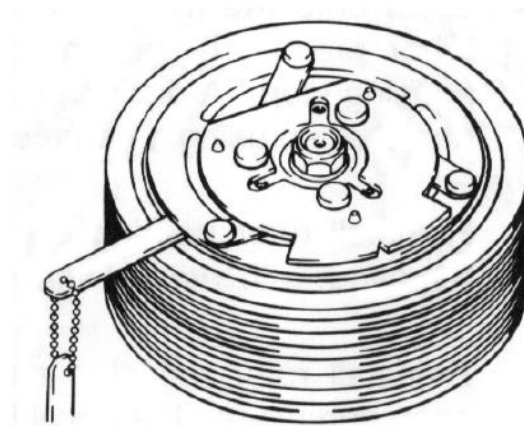

ILLUSTRATION 11.

3.2.5.4 Remove the bracket (1-14) from the defective compressor and attach the bracket to the replacement compressor and tighten.

3.2.5.5 Attach the rod end (1-6) of the turnbuckle to the bracket (1-14) on the compressor. Do not fully tighten at this time.



ZEE Systems, Inc.

COMPONENT MAINTENANCE MANUAL Z26-8900

3.2.5.6 Attach and adjust the belt as described in Section 3.1 through 3.1.6.

3.2.5.7 Check the operation of the clutch plate (1/7-16, 1/8-82) and coil (1/7-17, 1/8-81). If the wires are connected to a terminal block DO NOT apply power directly across pins C and D on the terminal block. Remove the (+) wire from the compressor coil at pin C on terminal block. Apply 28 VDC across the compressor coil (+) wire and pin D (-) on the terminal block. The clutch should pull into the pulley. Remove power and the clutch should release (move away) and the pulley will be free. Connect the coil (+) wire back to pin C on the terminal block. Refer to Wiring Diagram 1 for schematic. Resistance across the coil to ground should be 14.0 Ω - 18.2 Ω @ room temperature.

3.3 MOTOR, COMPRESSOR DRIVE (3-3) For complete overhaul instructions refer to CMM Z99-800 or CMM SZ58-003. Prior to disassembly mark the support positions (3-5/-8) for proper alignment during reassembly. The mounting holes are not centered on the supports (3-8/-5) and the motor is not centered between the angles.

NOTE

Use only the specified mounting hardware. Incorrect bolt Length can cause a short in the motor windings.

3.3.1 REMOVAL: Disconnect the positive and negative leads to the motor. Remove the clamp and all remaining attached wiring from the motor.

3.3.1.1 Remove and set aside the belt in accordance with paragraph 3.1.

3.3.1.2 Break the lock wire and remove the four bolts and hardware (1-30/-36/-39) that attach the supports to the angles (3-11/-12).

3.3.1.3 To remove the supports (3-5/-8) from the motor, loosen and remove the four bolts and hardware (3-25/-35/-37). Mark their position for proper reassembly.

3.3.1.4 Use a spanner wrench to hold the motor pulley (1-2/-4). Loosen and remove the bolt (3-28) and hardware (3-36/-39) spacer (3-1) and pulley. Inspect the motor pulley for damaged or rounded teeth. Replace if damaged.

3.3.2 BRUSH INSPECTION: Refer to Service Letter 58-001 or 99-800 for more detailed brush inspection information.

3.3.2.1 Brushes may be inspected without removing the motor from the installation. If possible remove the brush covers to reveal the brushes. If brushes are removed completely from the motor for inspection mark the location and return each brush to its original holder.

3.3.2.2 Lift the brush spring off the brush and slide the brush from the holder. The brush should slide easily in and out of the holder. If the brush is tight in the holder or if there is excessive side to side movement of the brush in the holder the motor should be removed for repair or overhaul.

3.3.2.3 Check each brush for chips, cracks, pitting, signs of arcing or overheating.



ZEE Systems, Inc.

COMPONENT MAINTENANCE MANUAL Z26-8900

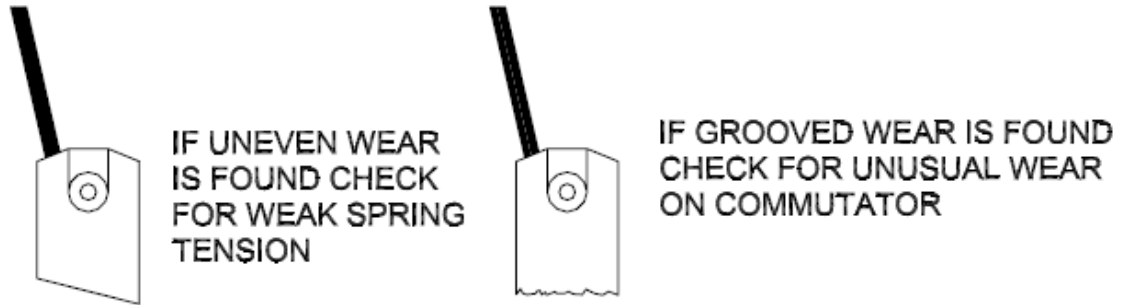

ILLUSTRATION 12.

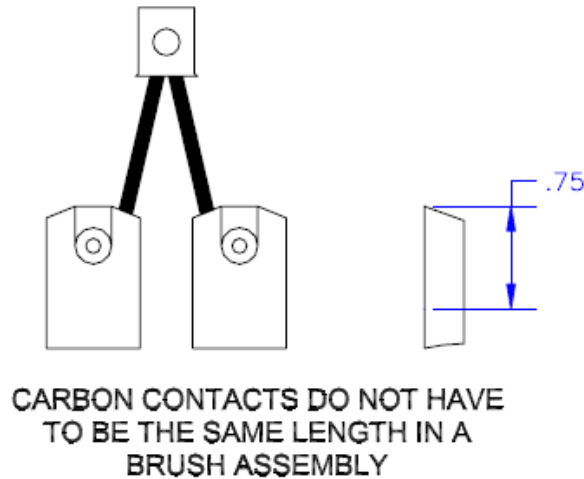

ILLUSTRATION 13.

3.3.2.4 With the brushes removed inspect the armature commutator for signs of overheating or unusual wear. A blackened film of carbon on the commutator is normal. Check for deep grooves or other signs of uneven wear on the commutator. Turn the armature by hand and check that there is no binding or end play. If any defect is noted the motor should be removed from service and repaired or overhauled.

3.3.2.5 When returning brushes to the holder gently lower the brush spring onto each brush. Do not drop the spring onto the top of the brush as damage to the brush may result.

3.3.3 **INSTALLATION:** Place the motor pulley on the shaft. Make sure the flats of the pulley mate with the flats on the motor shaft. Place the spacer and hardware (3-1/-36/-39) on the end of the pulley. Using a spanner wrench hold the motor pulley and tighten the bolt (3-28).



ZEE Systems, Inc.

COMPONENT MAINTENANCE MANUAL Z26-8900

3.3.3.1 Attach the supports (3-5/-8) and hardware (3-25/-35/-37) to the motor. Make sure they are aligned properly or the motor pulley will not be aligned with the compressor pulley. Tighten bolts and secure with lock wire.

3.3.3.2 Attach the supports (3-5/-8) and motor to the angles (3-11/-12), tighten and secure with lock wire.

3.3.3.3 Install and adjust the belt as described in section 3.1.

3.3.3.4 Attach wiring to motor. Refer to Wiring Diagram 1.

3.4 WIRING The Z26-8900 is part of the air conditioning system. The circuitry may include features to control the Condenser Power Fan, clutch, High/Low Pressure Switch to disengage the clutch should an unsafe pressure condition exist and a motor over-temp switch that will shut down the motor if the case temperature exceeds 450°F. The circuits may be connected through a Terminal Block which allows for easy replacement of components. Refer to the following diagrams for example circuit schematics.

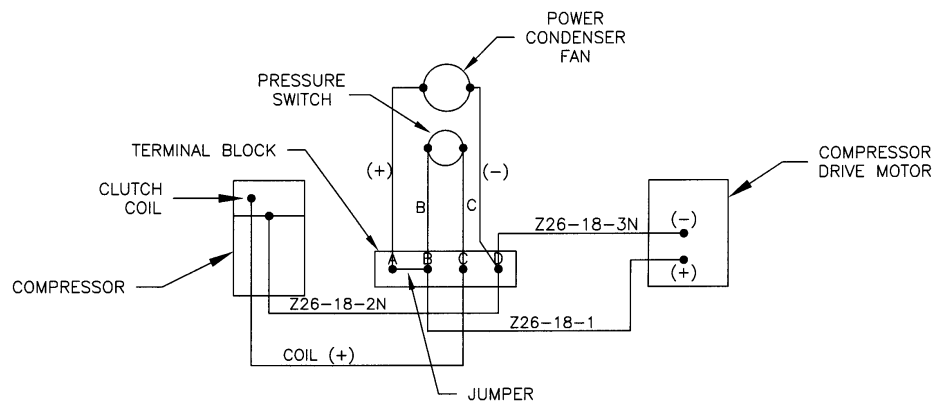

WIRING DIAGRAM 1.



ZEE Systems, Inc.

COMPONENT MAINTENANCE MANUAL Z26-8900

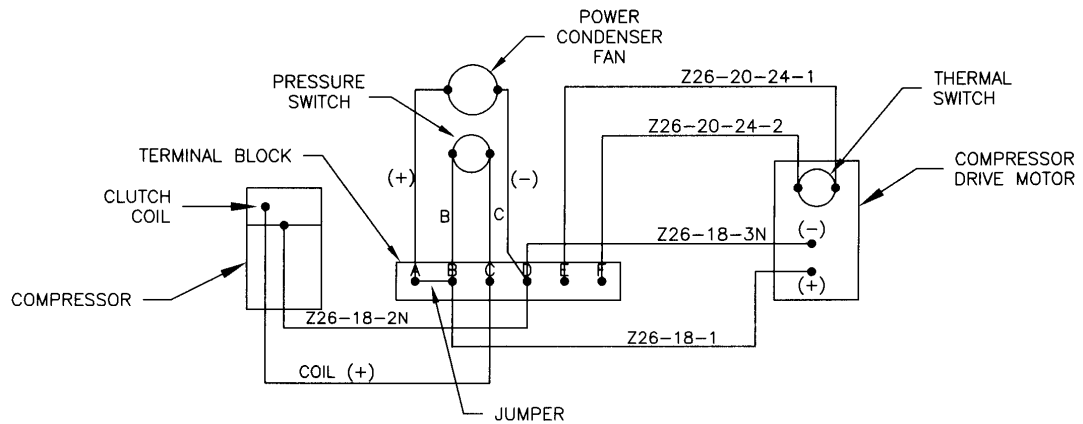

WIRING DIAGRAM 2.

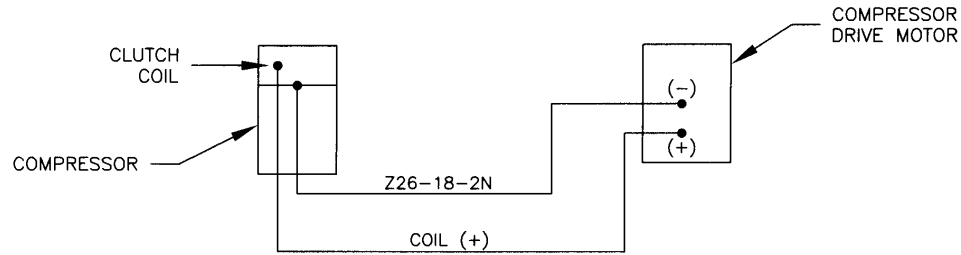

BASIC MINIMUM REQUIREMENT

WIRING DIAGRAM 3.

CAUTION

AIR CONDITIONING SYSTEM UNDER PRESSURE. APPROPRIATE SAFETY MEASURES SHOULD BE TAKEN WHEN SERVICING THIS EQUIPMENT. ONLY TRAINED PERSONNEL WITH APPROVED SAFETY EQUIPMENT SHOULD PERFORM SERVICING DUTIES.

NOTE

It is unlawful to release any refrigerants to the atmosphere. Use approved recovery/recycle equipment to capture refrigerants. Use only lawful means to dispose of recovered refrigerants. Check with local agencies for approved disposal procedures.

NOTE

Cap all open lines to prevent contaminants and moisture from entering the system.

4.0 SERVICING - REFRIGERANT CHARGE

4.1 Refer to Aircraft maintenance manual or ZEE Systems, Inc. Service Letter Z26-1 for recommended refrigerant charging service instructions.



ZEE Systems, Inc.

COMPONENT MAINTENANCE MANUAL Z26-8900

5.0 SERVICE SCHEDULES

5.1 MAINTENANCE SCHEDULE The maintenance and service schedules are ZEE Systems, Inc. recommended MAXIMUM intervals. Actual operating and environmental conditions may require more frequent service.

| ITEM DESCRIPTION | INSPECTION INTERVAL * | R&R/T.B.O. # HRS |
|-----------------------------|---|-----------------------------|
| Z26-8900 M-C | EVERY 250 HRS* - INSPECT FOR LOOSE, DAMAGED ITEMS.CHECK FOR SIGNS OF OIL LEAKS. | 2,000 |
| DRIVE BELT** | EVERY 250 HRS* - INSPECT AS PER SECTION 3.1.2 | 1,000 |
| MOTOR, DRIVE, ** COMPRESSOR | EVERY 1000 HRS* - INSPECT AS PER SECTION 3.3.2 AND SERVICE LETTER 58-001 or 99-800. REFER TO CMM SZ58-003 OR CMM Z99-800 FOR ADDITIONAL MAINTENANCE INFORMATION | 2,000 |
| COMPRESSOR** | (NEW) AFTER THE FIRST 100 HOURS - INSPECT AS PER SECTION 3.2.2.1 EVERY 500 HRS - INSPECT AS PER SECTION 3.2.2 | 2,000 |

MAXIMUM time between service.

* UNIT OPERATING TIME

** COMPONENT IS PART OF THE Z26-8900 MOTOR-COMPRESSOR ASSEMBLY. REFER TO SANDEN “SANDEN SD COMPRESSOR SERVICE MANUAL” FOR ADDITIONAL COMPRESSOR SERVICE INFORMATION.

6.0 TOLERANCES

6.1 COMPRESSOR OIL. NEW refer to *Illustration 9* and *10* and Table 1. For REPLACEMENT instructions refer to Section 3.2.2.2.

6.2 CLUTCH. When assembled an air gap of .016” - .031” (0.4 – 0.8mm) between the pulley and clutch plate.

6.3 REFRIGERANT CHARGE. Refer to aircraft maintenance manual or ZEE Systems, Inc. Service Letter Z26-1.

6.4 BRUSH LENGTH, COMPRESSOR DRIVE MOTOR. The minimum brush length on the drive motor is 0.750" (19mm). Refer to *Illustration 12* and *13*. Refer to SIL 58-001.

6.5 TORQUE VALUES. If not specified, use standard torque values for bolts.

14 mm Pulley Nut 11-15 lb-ft (15-21 N-m)

17 mm (10 mm Compressor Bolt) Nut 30 lb-ft (42 N-m)

7.0 TROUBLE SHOOTING



ZEE Systems, Inc.

COMPONENT MAINTENANCE MANUAL Z26-8900

| TROUBLE | POSSIBLE CAUSE | REMEDY |
|---|---|---|
| Compressor Motor trips circuit breaker or current limiter | Motor shorted. Motor brushes worn beyond limits. | Replace Motor. |
| | Short in wiring. | Check wiring to motor, repair as required. |
| Compressor Motor inoperative. | Motor open. Motor brushes worn beyond limits. | Replace Motor. |
| | Short in wiring. | Check wiring to motor, repair as required. |
| Excessive vibration at Motor/Compressor. | Improper belt tension. | Adjust belt to correct tension. |
| | Worn, damaged or loose or over tightened mounts. | Adjust or replace mounts. |
| Quick refrigerant loss. | Open in system. | Check compressor head gasket. Check Hoses or tubing for holes. Check connections. Replace defective component. Service system |
| | Defective O-Ring. | Replace defective O-Ring. Service system |
| | Loose connections. | Tighten connections. Service system |
| Slow refrigerant loss. | Loose connections. | Tighten connections. Service system |
| Low or no cooling. Low Pressures. | Incorrect Back Seat Valve position. | Place Back Seat Valve In proper position for normal operation. |
| | Low refrigerant. | Service as necessary. |



ZEE Systems, Inc.

COMPONENT MAINTENANCE MANUAL Z26-8900

| TROUBLE | POSSIBLE CAUSE | REMEDY |
|---|----------------------------------|--|
| Compressor clutch does not engage. | Low or high discharge pressures. | Check refrigerant charge. Service as necessary. |
| | Defective Pressure Switch | Replace Pressure Switch. |
| | Defective Coil. | Replace Coil. |
| | Defective wiring. | Refer to Diagram 1. Repair as necessary. |
| MC and Clutch start up normally. Clutch disengages after a short time. | Power Condenser Fan defective. | Replace Power Condenser Fan Assembly. |



ZEE Systems, Inc.

COMPONENT MAINTENANCE MANUAL Z26-8900

8.0 ILLUSTRATED PARTS LIST

8.1 EXPLANATION OF SYMBOLS:

ALT - The Part Number shown is an approved alternate, either part number may be used.

MOD "X" Refers to modification information of this part as applicable to this assembly.

NP - Not Procurable individually, see next higher assembly.

NS - Not Shown

OBS - Obsolete

USAGE/QTY - This identifies parts used on specific applications (not common to all units). If no code is stated the part is common to all dash numbers.

.. - Part of higher assembly.

*/# - See explanation at end of parts list.

“AN”, “MS” and “NAS” equivalent hardware is considered to be approved alternates for each other and may be used. The most common are as follows:

| PART NUMBER | ALTERNATE | DESCRIPTION |
|-------------|---------------|--------------|
| AN345-516 | MS35650-3312 | NUT, MACHINE |
| AN364-624A | MS21083N6 | LOCK NUT |
| AN365-428A | MS21044N4 | LOCK NUT |
| AN365-832A | MS21044N08 | LOCK NUT |
| AN501A10-6 | MS35266-61 | SCREW |
| AN935-416 | MS35338-44 | WASHER, LOCK |
| AN935-516 | MS35338-45 | WASHER, LOCK |
| AN935-616 | MS35338-46 | WASHER, LOCK |
| AN935-8 | MS35338-42 | WASHER, LOCK |
| AN960-416 | NAS1149F0463P | WASHER, FLAT |
| AN960-416L | NAS1149F0432P | WASHER, FLAT |
| AN960-516 | NAS1149F0563P | WASHER, FLAT |
| AN960-516L | NAS1149F0532P | WASHER, FLAT |
| AN960-616 | NAS1149F0663P | WASHER, FLAT |
| AN960-616L | NAS1149F0632P | WASHER, FLAT |
| AN960-8L | NAS1149FN816P | WASHER, FLAT |



ZEE Systems, Inc.

COMPONENT MAINTENANCE MANUAL Z26-8900

8.2 ILLUSTRATED PARTS LIST Z26-8900 MOTOR COMPRESSOR ASSEMBLY.

| FIG-ITEM | PART NUMBER | NOMENCLATURE | QTY | USAGE CODE | NOTES |
|-----------------|--------------------|---------------------------|--------------------------|-----------------------|--------------|
| 1/2/3/4 | Z26-8900-1 | Motor Compressor Assembly | | A | |
| | Z26-8900-2 | Motor Compressor Assembly | | B | |
| | Z26-8900-3 | Motor Compressor Assembly | | C | |
| | Z26-8900-4 | Motor Compressor Assembly | | D | |
| | Z26-8900-5 | Motor Compressor Assembly | | E | |
| | Z26-8900-6 | Motor Compressor Assembly | | F | |
| | Z26-8900-7 | Motor Compressor Assembly | | G | |
| | Z26-8900-8 | Motor Compressor Assembly | | H | |
| | Z26-8900-9 | Motor Compressor Assembly | | J | |
| -1 | SZ41-019-5 | Spacer | 1 | A,B,E,F,G,H,J | |
| -2 | SZ43-008-3 | Pulley, Motor | 1 | A,B,E,G,H,J | |
| -3 | SZ58-003-1 | Motor | 1 | A,B,F,G | |
| | SZ58-003-2 | Alternate | | | |
| -4 | SZ83-041-4 | Pulley | 1 | C,D | |
| | | Alternate | | G | MOD H |
| -5 | Z14-401-1 | Support | 2 | | |
| -6 | Z25-404-1 | Clevis | 1 | | |
| -7 | Z25-404-2 | Rod End | 1 | | |
| -8 | Z26-400-1 | Support | 2 | | |
| -9 | Z26-401-1 | Spacer | 1 | | |
| -10 | Z26-401-2 | Spacer | 1 | | |
| -11 | Z26-402-1 | Angle | 1 | A,B,C,D,E,F | |
| -12 | Z26-402-2 | Angle | 1 | A,B,C,D,E,F | |
| -13 | Z26-403-1 | Bracket | 1 | | |
| -14 | Z26-404-1 | Bracket | 1 | | |
| -15 | Z26-405-1 | Turnbuckle Barrel | 1 | A,B,E,G,H,J | |
| 7 | -16 | Z99-421-7 | Clutch Plate | 1 | |
| 7 | -16A | SD5H09-SHIM | Shim | AR | |
| 7 | -16B | SD5H09-RET-A | Snap Ring | 1 | |
| 7 | -17 | Z99-421-9 | Coil Assy | 1 | 5 |
| 7 | -17A | SD5H09-RET-B | Snap Ring | 1 | |
| 7 | -18 | Z99-423-1 | Pulley Assy | 1 | 4 |
| 7 | -18A | Z99-840-13 | Bearing | 1 | |
| 7 | -18B | SD5H09-RET-C | Snap Ring | 1 | |
| 7 | -19 | Z99-915-4 | Compressor | 1 | |
| 7 | | Z99-915-40 | Compressor & Pulley Assy | | 2 |
| 7 | -19A | SD5H09-KEY | Key | 1 | |
| 7 | -19B | MS35206-243 | Screw | 1 | |
| 7 | -19C | MS35338-42 | Washer, Lock | 1 | |
| 7 | -19D | SD5H09-CLIP | Clip | 1 | |
| 7 | -19E | SD5H09-BOLT | Bolt | 1 | |
| 7 | -19F | MS28775-011 | O-Ring | 1 | |



ZEE Systems, Inc.

COMPONENT MAINTENANCE MANUAL Z26-8900

| FIG-ITEM | PART NUMBER | NOMENCLATURE | QTY | USAGE CODE | NOTES |
|-----------------|--------------------|----------------------|------------|-------------------|--------------|
| 1/2/3/4 | | | | | |
| -20 | 255L075 | Belt | 1 | A,B,E,F,G,H,J | |
| -21 | 270L100 | Belt | 1 | C,D | |
| | | Alternate | | G | MOD H |
| -22 | 400649-1 | I.D. Plate | 1 | | |
| -23 | 8M-1.25 | Nut, Lock, Metric | 1 | | |
| -24 | AN4-5A | Bolt | 2 | | |
| -25 | AN4H17A | Bolt | 4 | | |
| -26 | AN5-11A | Bolt | 1 | | |
| -27 | AN5-12A | Bolt | 1 | | |
| -28 | AN6-6A | Bolt | 1 | | |
| -29 | AN6-11A | Bolt | 2 | | |
| -30 | AN76A11 | Bolt | 4 | | |
| | MS20074-06-11 | Alternate | | | |
| -31 | MS20995C025 | Lock Wire | AR | | |
| -32 | MS21045-5 | Nut, Lock | 2 | | |
| -33 | MS21045-6 | Nut, Lock | 2 | | |
| -34 | MS21251B6S | Turnbuckle Barrel | 1 | C,D | |
| | | Alternate | | G | MOD H |
| -35 | MS35338-44 | Washer, Lock | 6 | | |
| | AN935-416 | Alternate | | | |
| -36 | MS35338-46 | Washer, Lock | 5 | | |
| | AN935-616 | Alternate | 9 | G | |
| -37 | NAS1149F0463P | Washer, Flat | 6 | | |
| | AN960-416 | Alternate | | | |
| -38 | NAS1149F0563P | Washer, Flat | 4 | | |
| | AN960-516 | Alternate | | | |
| -39 | NAS1149F0663P | Washer, Flat | 9 | | |
| | AN960-616 | Alternate | | | |
| -40 | NAS509-5R | Nut, Jam | 1 | | |
| -41 | NAS509-5L | Nut, Jam | 1 | | |
| -42 | M10 | Washer, Flat, Metric | 2 | | |
| -43 | 10M-1.50 | Nut, Lock, Metric | 1 | | |
| -44 | 10M-1.5x150mm | Bolt, Metric | 1 | | |
| -45 | AN316-6R | Nut | 2 | | |
| -46 | NAS1149F0632P | Washer, Flat | 4 | | |
| | AN960-616L | Alternate | 8 | G | |
| -47 | 400649-1 | I.D. Plate | 1 | | |
| -48 | Z99-800-1 | Motor | 1 | E,H,J | |
| | Z99-800-1 MOD E | Alternate | | E | MOD A |
| -49 | Z26-405-2 | Turnbuckle Barrel | 1 | A,F | MOD J, K |
| -50 | SZ41-033-1 | Pulley | 1 | F | |
| -51 | Z26-402-3A | Angle | 1 | G | |



ZEE Systems, Inc.

COMPONENT MAINTENANCE MANUAL Z26-8900

| FIG-ITEM | PART NUMBER | NOMENCLATURE | QTY | USAGE CODE | NOTES |
|-----------------|--------------------|---------------------|------------|-----------------------|--------------|
| 1/2/3/4 | | | | | |
| | Z26-402-3 | Alternate | | | 1, MOD C |
| | Z26-402-5 | Alternate | | | MOD F |
| -52 | Z26-402-4A | Angle | 1 | G | |
| | Z26-402-4 | Alternate | | | 1, MOD C |
| | Z26-402-6 | Alternate | | | MOD F |
| -53 | SZ58-019-3 | Shock Mount | 4 | H,J | |
| -54 | SZ96-300-1 | Channel Mount | 2 | H,J | |
| -55 | AN74A3 | Bolt | 8 | G,H,J | |
| -56 | N-3 | Clamp | 3 | G | |
| | | | 2 | H,J | |
| -57 | MS35206-245 | Screw | 2 | G,H,J | |
| -58 | MS35338-42 | Washer, Lock | 2 | G,H,J | |
| | AN935-8 | Alternate | | | |
| -59 | MS35649-2382 | Nut | 4 | G,H,J | |
| | AN340-616 | Alternate | | | |
| -60 | NAS1096-2-14 | Screw | 2 | G,H,J | |
| -61 | NAS1149F0432P | Washer, Flat | 8 | G,H,J | |
| | AN960-416L | Alternate | | | |
| -62 | NAS1149F0816P | Washer, Flat | 4 | G | |
| | | | 2 | H,J | |
| | AN960-8L | Alternate | | | |
| -63 | Z26-407-1 | Angle | 1 | H,J | |
| -64 | Z26-407-2 | Angle | 1 | H,J | |
| -65 | SZ96-300-1B | Channel Mount | 2 | G | |
| | | Alternate | | G | MOD H |
| -66 | Z26-402-5 | Angle | 1 | G | |
| | | Alternate | | G | MOD H |
| -67 | Z26-402-6 | Angle | 1 | G | |
| | | Alternate | | G | MOD H |
| -68 | Z26K031-4 | Terminal Block | 1 | G | |
| | | Alternate | | G | MOD H |
| -69 | SZ41-019-11 | Spacer | 1 | A | MOD L |
| | | Spacer | 1 | G | MOD H |
| -70 | SZ58-019-5 | Shock Mount | 3 | G | |
| | | Alternate | | G | MOD H |
| -71 | SZ58-019-6 | Shock Mount | 1 | G | |
| | | Alternate | | G | MOD H |
| -72 | Z26-040-1 | Safety Bolt | 2 | G | |
| | | Alternate | | G | MOD H |
| -73 | AN315-5R | Jam Nut | 2 | G | |
| | | Alternate | | G | MOD H |



ZEE Systems, Inc.

COMPONENT MAINTENANCE MANUAL Z26-8900

| FIG-ITEM | PART NUMBER | NOMENCLATURE | QTY | USAGE CODE | NOTES |
|-----------------|--------------------|------------------------------|------------|-------------------|--------------|
| 1/2/3/4 | | | | | |
| | -74 | MS21044N08 | 2 | G | |
| | | Lock Nut | | | |
| | | Alternate | | G | MOD H |
| 5 | -75 | Z26-200-8 | 1 | | MOD D |
| | | Back Seat Valve | | | |
| | | ..MS28775-013 | 1 | | |
| | | O-Ring | | | |
| 5 | -76 | Z26-200-10 | 1 | | MOD D |
| | | Back Seat Valve | | | |
| | | ..MS28775-015 | 1 | | |
| | | O-Ring | | | |
| 5 | -77 | Z26-200-8A | 1 | | MOD E |
| | | Back Seat Valve w/HSP | | | |
| | | ..MS28775-013 | 1 | | |
| | | O-Ring | | | |
| 5 | -78 | Z26-200-10A | 1 | | MOD E |
| | | Back Seat Valve w/LSP | | | |
| | | ..MS28775-015 | 1 | | |
| | | O-Ring | | | |
| 6/8 | -79 | Z99-915-2 | 1 | A | MOD J |
| | | Compressor | | | |
| | | Z99-915-20 | 1 | | 3 |
| | | Compressor & Pulley Assembly | | | |
| 6/8 | -79A | SD5H14-KEY | 1 | A | MOD J |
| | | Key | | | |
| 6/8 | -79B | MS35206-243 | 1 | A | MOD J |
| | | Screw | | | |
| 6/8 | -79C | MS35338-42 | 1 | A | MOD J |
| | | Washer, Lock | | | |
| 6/8 | -79D | SD5H14-CLIP | 1 | A | MOD J |
| | | Clip | | | |
| 6/8 | -79E | SD5H14-BOLT | 1 | A | MOD J |
| | | Bolt | | | |
| 6/8 | -79F | MS28775-011 | 1 | A | MOD J |
| | | O-Ring | | | |
| 6/8 | -80 | Z99-425-1 | 1 | A | 6,MOD J |
| | | Pulley | | | |
| 6/8 | -80A | Z99-840-15 | 1 | A | MOD J |
| | | Bearing | | | |
| 6/8 | -80B | SD5H14-RET-C | 1 | A | MOD J |
| | | Snap Ring | | | |
| 6/8 | -81 | Z99-425-9 | 1 | A | 7, MOD J |
| | | Coil | | | |
| 6/8 | -81A | SD5H14-RET-B | 1 | A | MOD J |
| | | Snap Ring | | | |
| 6/8 | -82 | Z99-425-7 | 1 | A | MOD J |
| | | Clutch | | | |
| 6/8 | -82A | SD5H14-SHIM | 1 | A | MOD J |
| | | Shim | | | |
| 6/8 | -82B | SD5H14-RET-A | 1 | A | MOD J |
| | | Snap Ring | | | |
| 6 | -83 | SZ83-041-3 | 1 | A | MOD J, K |
| | | Pulley | | | |
| 6 | -84 | Z26-401-3 | 1 | A | MOD J |
| | | Spacer | | | |
| 6 | -85 | Z26-401-4 | 1 | A | MOD J |
| | | Spacer | | | |
| 6 | -86 | 10-1.5x160 | 1 | A | MOD J |
| | | Bolt | | | |
| 6 | -87 | 8M-1.25 | 1 | A | MOD J |
| | | Nut, Lock, Metric | | | |
| 6 | -88 | AN5-15A | 1 | A | MOD J |
| | | Bolt | | | |
| 6 | -89 | AN6-12A | 2 | A | MOD J |
| | | Bolt | | | |
| 6 | -90 | Z26-401-5 | 1 | A | MOD J |
| | | Spacer | | | |
| 6 | -91 | Z30-403-1 | 1 | A | MOD J |
| | | Spacer | | | |
| 6 | -92 | 263L100 | 1 | A | MOD J,K,L |
| | | Belt | | | |
| 1/4/6 | -93 | SZ83-041-6 | 1 | A | MOD L |
| | | Pulley, Motor | | | |
| 4 | -94 | SZ83-041-8 | 1 | G | MOD M |
| | | Pulley, Motor | | | |
| 4 | -95 | SZ41-019-13 | 1 | G,H | MOD M |
| | | Spacer | | | |
| 4 | -96 | SZ96-302-1 | 1 | G | MOD M |
| | | Channel | | | |
| 4 | -97 | SZ96-302-2 | 1 | G | MOD M |
| | | Channel | | | |

NOTE 1. Must be match drilled to base plate.

NOTE 2. Z99-915-40 includes all items 16 thru 19F & 23 as an assembly. Parts may be ordered individually.



ZEE Systems, Inc.

COMPONENT MAINTENANCE MANUAL Z26-8900

NOTE 3. Z99-915-20 includes all items 79 thru 82B & 87 as an assembly. Parts may be ordered individually.

NOTE 4. New replacement -18 Pulley Assy comes assembled with the -18A Bearing and -18B Snap Ring installed

NOTE 5. New replacement -17 Coil Assy is supplied with a new -17A Snap Ring.

NOTE 6. New replacement -80 Pulley Assy comes assembled with the -80A Bearing and -80B Snap Ring installed

NOTE 7. New replacement -81 Coil Assy is supplied with a new -81A Snap Ring.



ZEE Systems, Inc.

COMPONENT MAINTENANCE MANUAL Z26-8900

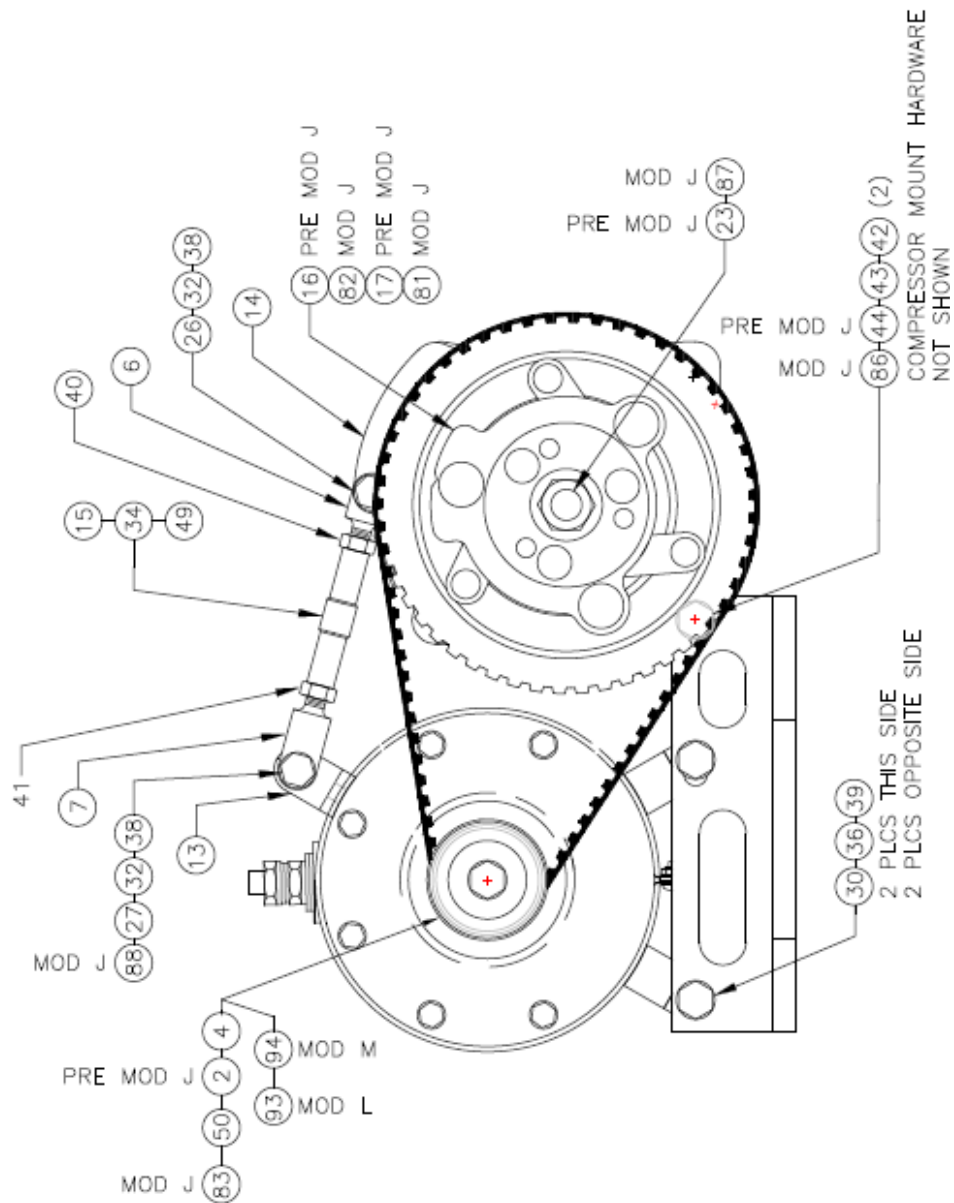

FIG. 1



ZEE Systems, Inc.

COMPONENT MAINTENANCE MANUAL Z26-8900

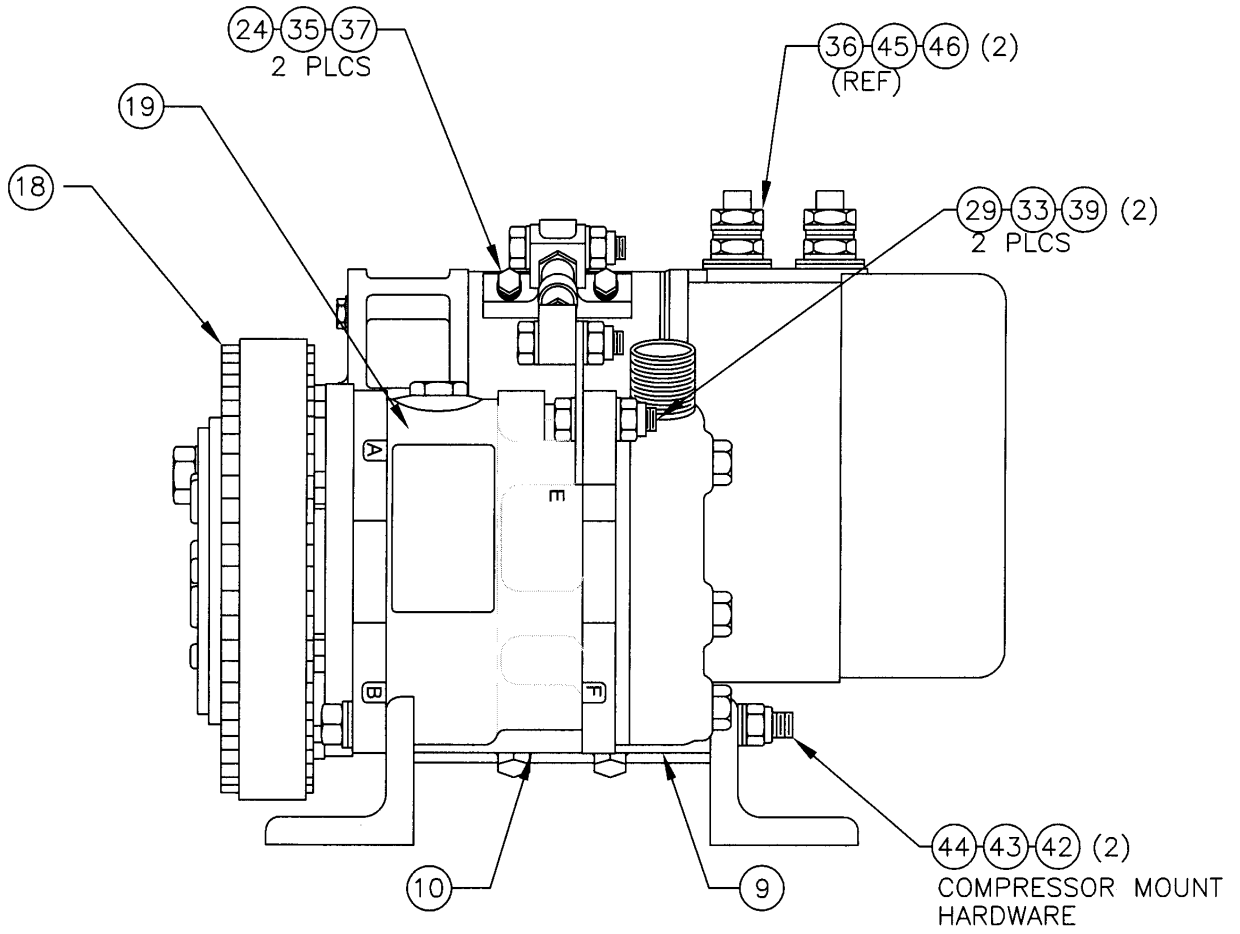

FIG. 2



ZEE Systems, Inc.

COMPONENT MAINTENANCE MANUAL Z26-8900

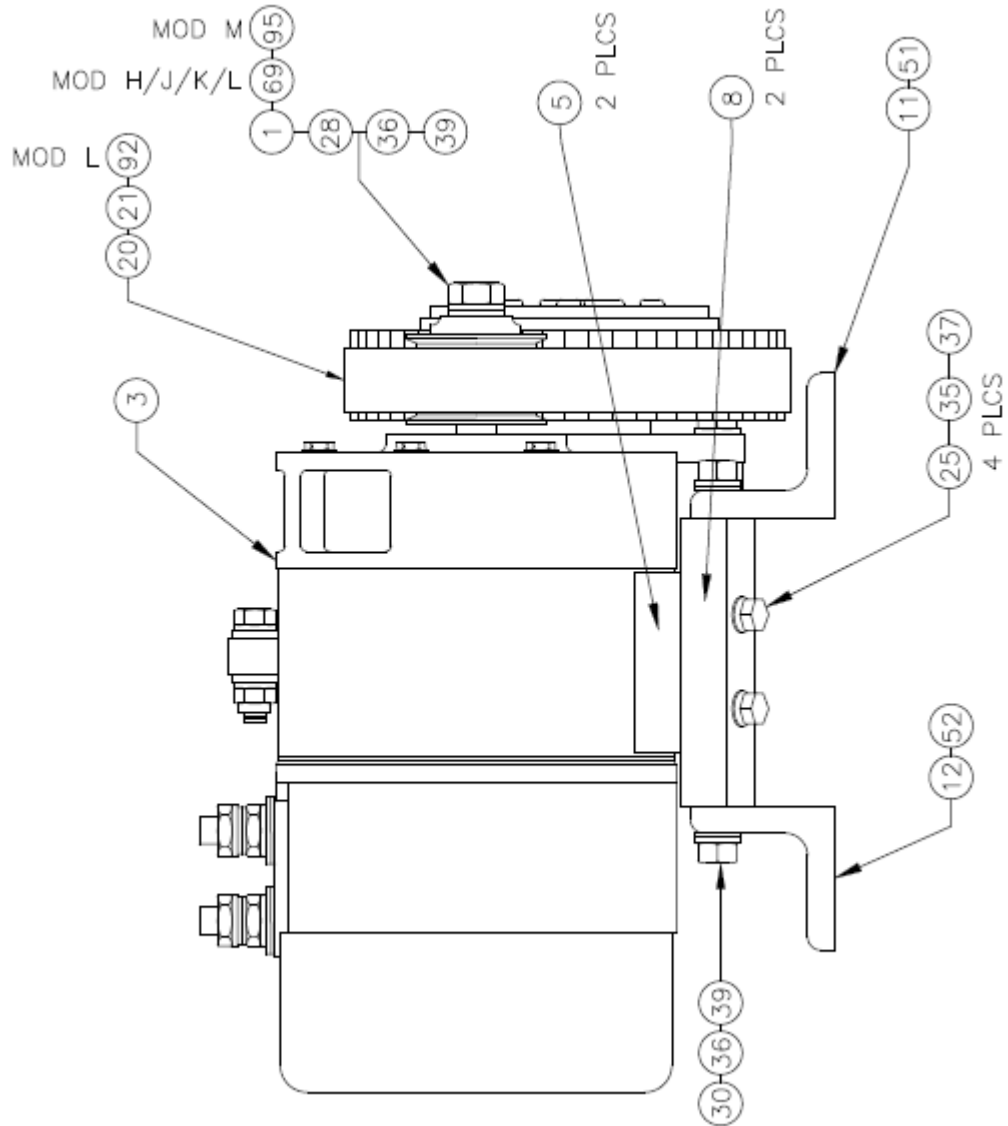

FIG. 3



ZEE Systems, Inc.

COMPONENT MAINTENANCE MANUAL Z26-8900

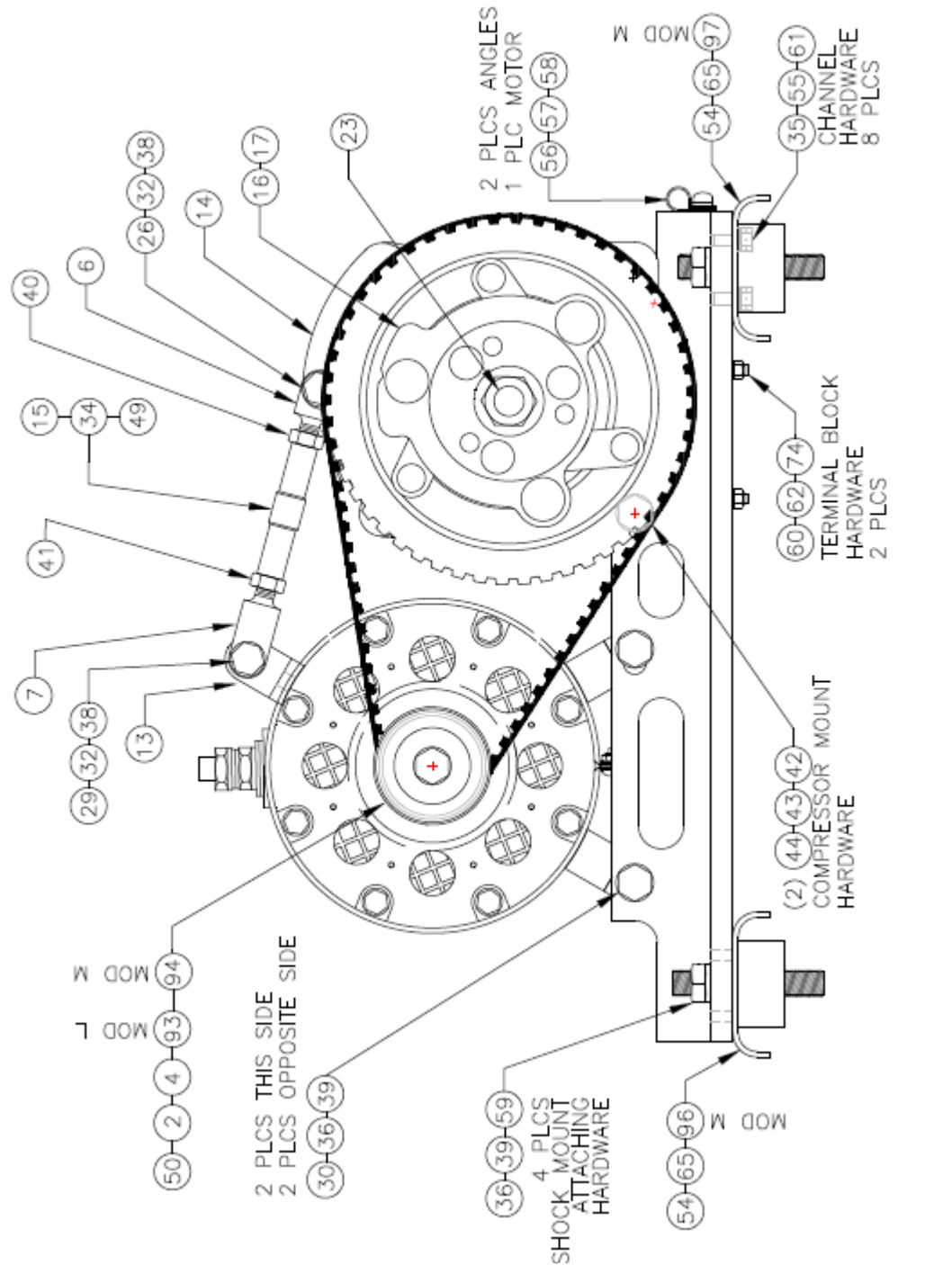

FIG. 4



ZEE Systems, Inc.

COMPONENT MAINTENANCE MANUAL Z26-8900

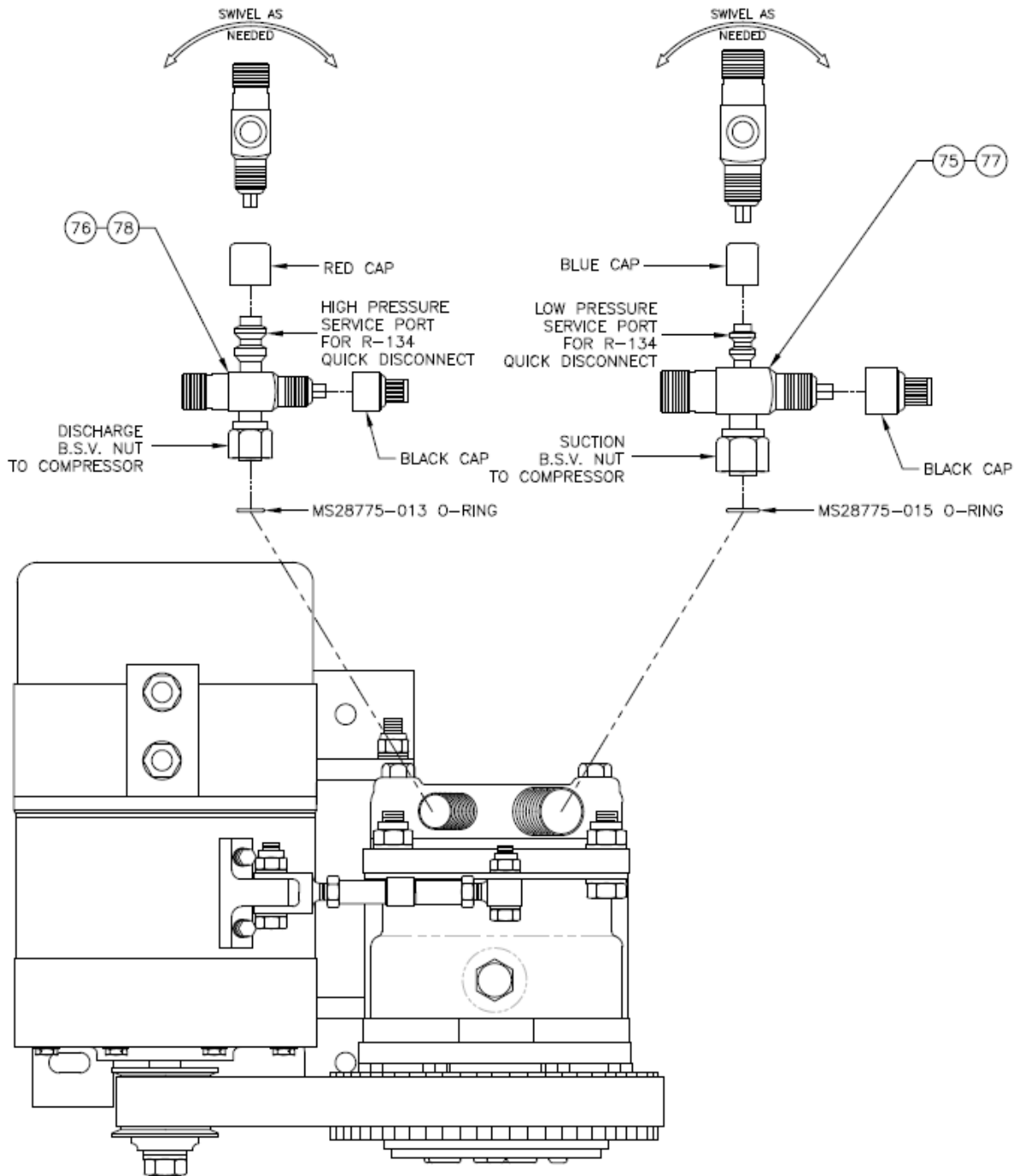

FIG. 5



ZEE Systems, Inc.

COMPONENT MAINTENANCE MANUAL Z26-8900

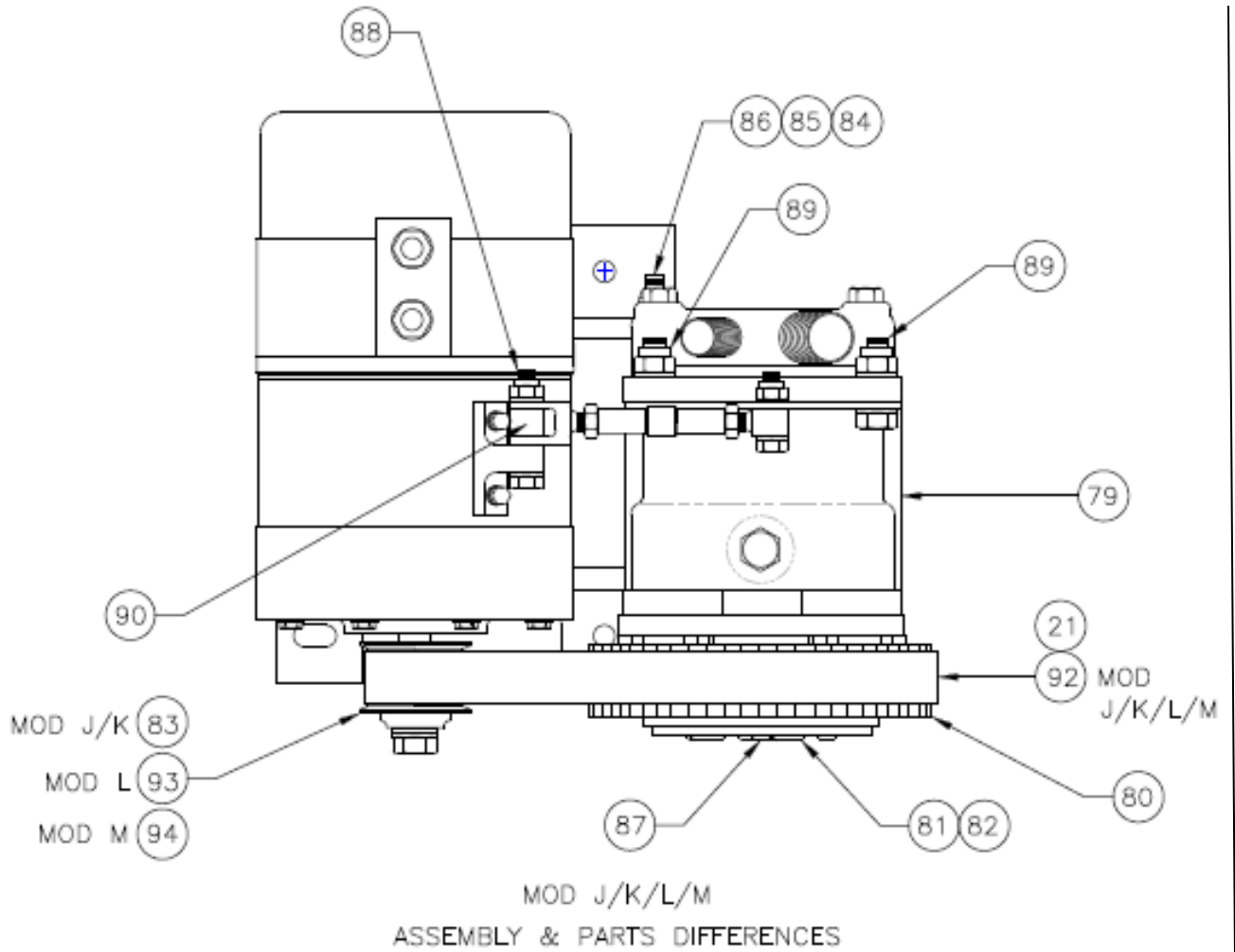

FIG. 6



ZEE Systems, Inc.

COMPONENT MAINTENANCE MANUAL Z26-8900

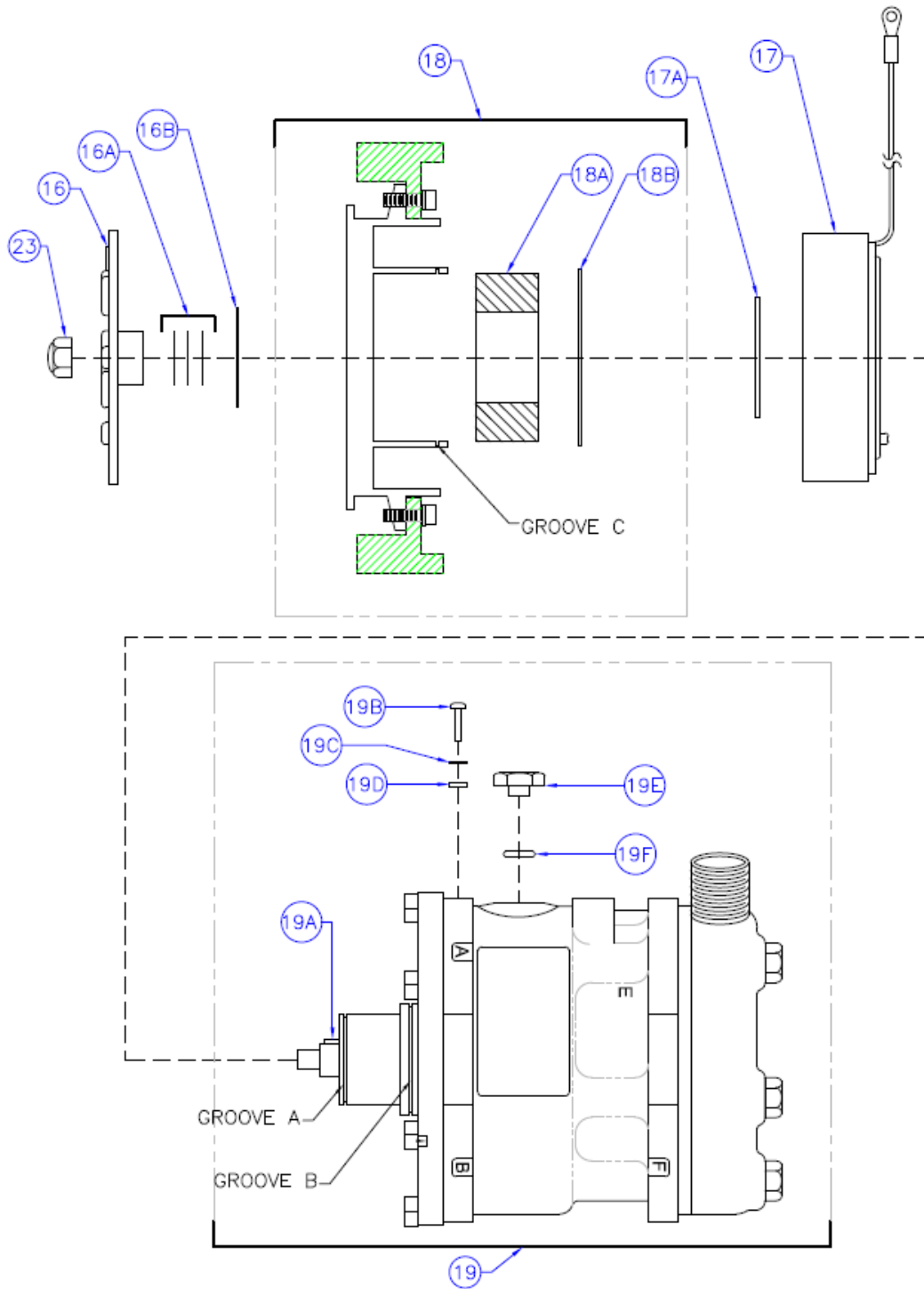

FIG. 7



ZEE Systems, Inc.

COMPONENT MAINTENANCE MANUAL Z26-8900

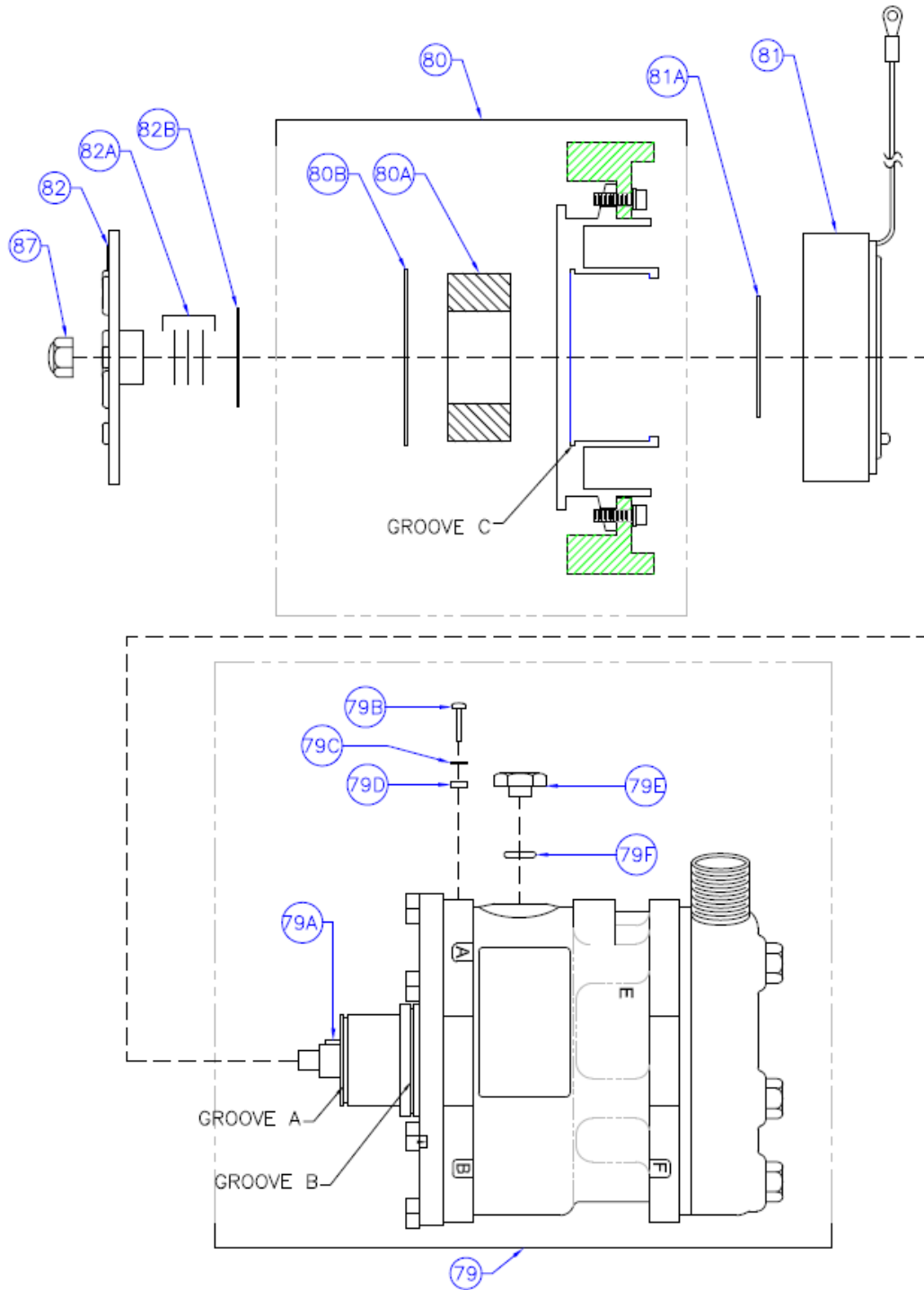

FIG. 8



ZEE Systems, Inc.

COMPONENT MAINTENANCE MANUAL Z26-8900

9.0 SUMMARY OF MODIFICATIONS

9.1 MOD "A". This modification applies to the Z26-8900-5 Assembly ONLY. The modification is noted when the Z99-800-1 Motor used has MOD E.

9.2 MOD "B". This modification allows the MC to use R-12 (Freon) refrigerant. Identify by marking an "X" in the on the MOD block on the I.D. Plate when using R-12 refrigerant. Also mark "R12" at the end of the serial number before any ending dash number.

9.3 MOD "C". This modification applies to Z26-8900-7 Assembly ONLY. This mod identifies when using angles items -51 and -52. And match drilled to the base plate. When using -3A and -4A angles no modification in noted.

9.4 MOD "D". Install Z26-200-8 and Z26-200-10 Back Seat Valves on the compressor.

9.5 MOD "E". Install Z26-200-8A and Z26-200-10A Back Seat Valves on the compressor.

9.6 MOD "F". This modification applies to the Z26-8900-7 Assembly ONLY. Use 1each Z26-402-5 and Z26-402-6 Angles.

9.7 MOD "G". Supply 1each Z26K031-4 Terminal Block Kit with the Z26-8900-(Any Dash).

9.8 MOD "H". This modification applies to the Z26-8900-7 Assembly ONLY. Install items 4, 21, 34 and 65 through 74.

9.9 MOD "I". Skip

9.10 MOD "J". This modification applies to the Z26-8900-1 Assembly ONLY. Install items 21, 79 through 90. Delete items 2, 9, 10, 15 through 20, 23 and 24.

9.11 MOD "K". This modification applies to the Z26-8900-1 Assembly ONLY. Install items 49, 83 and 92. Delete items 15, 18 and 21.

9.12 MOD "L". Install item 69, 92, 93. Delete any other motor pulley call out when this mod is used.

9.12 MOD "M". Install items 93, 94, 96 and 97. Delete any other motor pulley call out when this mod is used.

10.0 REVISION SUMMARY

10.1 REVISION 1: Add MODS D, E, F, G, H, J, K into CMM. Add Z26-8900-8 & -9 to CMM. Add Section 8.3, Figures 4, 5, 6, 7 and 8.

10.2 REVISION 2: Revise Section 3 to include Figure 7 and 8 items. Add Illustration in Section 3.2. Renummer Illustrations 11 & 12 to 12 & 13. Delete Section 8.3. Revise Figure 6 to show MOD L.



ZEE Systems, Inc.

COMPONENT MAINTENANCE MANUAL Z26-8900

Renumber items in Figures 7 and 8. Add MOD L. Add Section 9.12. Bar in right margin marks revision locations.

10.3 REVISION 3: Add MOD M. Revise Figure X to show MOD M.

10.4 REVISION 4. Clarify MOD L parts. Update FIG. 1 & 3 & 6.