



ZEE Systems, Inc.

SERVICE BULLETIN R134-06

1.0 EFFECTIVITY: DC-3 aircraft that have been modified in accordance with Basler Turbo Conversions STC SA1734GL for the installation of ZEE Systems, Inc. air conditioning equipment.

2.0 PURPOSE: To modify the air conditioning system to use R-134a refrigerant.

2.1 Description: This service bulletin gives instructions for converting the components and system to use the R134a (HFC-134a) refrigerant. Assemblies manufactured after December 1997 will use E.P.A. accepted R-134a as the standard refrigerant. Assemblies manufactured after September 2006 will have all appropriate modifications to components incorporated during manufacture. Service Bulletins SB 83-001-2, SB 78-001-1 and SB R134-06 must all be accomplished to convert the air conditioning system to R134a refrigerant from R-12 (Freon).

2.2 New Installation: Install equipment as normal R-12 system. Refer to Service Bulletin R134-06 for additional modification instructions to allow the use R-134a refrigerant for equipment installed under STC SA1734GL.

2.3 Modification of existing system: This conversion consists of replacing components and servicing with R-134a refrigerant.

3.0 COMPLIANCE: Compliance is optional for existing R-12 systems. Systems manufactured and installed after September 2006 will have all appropriate modifications to components incorporated during manufacture.

4.0 APPROVALS: This service bulletin contains no modification data that changes the fit, form or function of the original design and therefore does not require any additional approvals. There are no changes to the operating characteristics of the air conditioning equipment. There is no part number change.

5.0 WEIGHT AND BALANCE: The air conditioning system becomes approximately 7 lbs lighter.

6.0 ELECTRICAL LOAD DATA: No change.

7.0 SPECIAL TOOLS AND EQUIPMENT: Equipment used in Discharging and Charging the system.

Refrigerant Recovery/Recycle Equipment meeting SAE J1990 or J2209 specifications.	Commercially Available
Manifold Gauge Set, with hoses R-134a compatible	Commercially Available
Scale .1 lb. increments	Commercially Available
Leak Detector for R134a refrigerant	Commercially Available
Vacuum Pump	Commercially Available
Temperature Measuring Devices	Commercially Available
R-134a (HFC-134a) Refrigerant	Commercially Available



ZEE Systems, Inc.

SERVICE BULLETIN R134-06

Sanden SP-20 or PAG-100 Oil

Commercially Available

8.0 MANPOWER REQUIREMENTS:

8.1 New Installation: When incorporating this service bulletin during new manufacture no additional man hours are required over the normal installation time.

8.2 Modification of existing system: No man hour estimates are available at this time. This upgrade will require the MCC Assembly P/N: SZ83-001 and the SZ78-001 Evaporator Assembly be returned to ZEE Systems, Inc. for modification. The modified MCC and Evaporator Assembly will be reinstalled.

9.0 INSTRUCTIONS: The MCC and Evaporator must be removed from the aircraft and returned to ZEE Systems, Inc. for modification. Refer to STC information for instructions.

9.1 Removal of R-12 components. It is advisable to make notes or take photographs of the equipment prior to disassembly.

CAUTION

SYSTEM IS UNDER PRESSURE. APPROPRIATE SAFETY MEASURES SHOULD BE TAKE WHEN SERVICING THIS EQUIPMENT. ONLY TRAINED PERSONNEL WITH SAFETY EQUIPMENT SHOULD PERFORM THESE DUTIES.

NOTE

IT IS UNLAWFUL TO RELEASE R-12 TO THE ATMOSPHERE. USE APPROVED RECOVERY/RECYCLE EQUIPMENT TO CAPTURE THE R-12. USE ONLY LAWFUL MEANS TO DISPOSE OF RECOVERED R-12. CHECK WITH LOCAL AGENCIES FOR APPROVED DISPOSAL PROCEDURES.

NOTE

CAP ALL LINES TO PREVENT CONTAMINANTS AND MOISTURE FROM ENTERING THE SYSTEM.

NOTE

USE A BACKUP WRENCH WHEN LOOSENING OR TIGHTENING FITTINGS. DO NOT OVER TIGHTEN.

9.1.1 Recover the refrigerant from the system.

9.1.2 Disconnect and remove the SZ83-001 MCC, SZ78-001 Evaporator, SZ41-016 Modulator Valve, 7-8159 Receiver Dryer and all Plumbing from the aircraft.

9.1.3 Return the MCC and Evaporator and plumbing components to ZEE Systems, Inc. for modification. No field modification is available for these components.



ZEE Systems, Inc.

SERVICE BULLETIN R134-06

9.2 Installation of R134a components.

9.2.1 Install the modified MCC into the aircraft.

9.2.1.1 Add 3 oz. of PAG-100 oil to condenser coil on the SZ83-001 Motor Compressor Condenser prior to installation. Add the oil through the inlet (top) or exhaust (bottom) header tubes.

9.2.1.2 The compressor is supplied serviced and ready to use. To check the oil level in the compressor, fabricate a dip stick as shown below. Determine angle of the compressor relative to level. Align the clutch as shown below. Remove the oil fill plug at the top of the compressor. Insert the dip stick and determine oil level using TABLE 1. Add oil as necessary. Replace the oil fill plug.

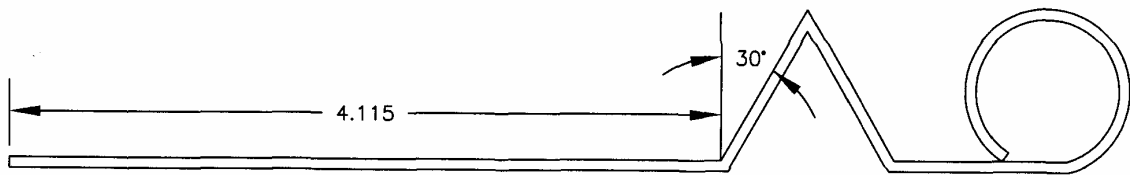

DIP STICK

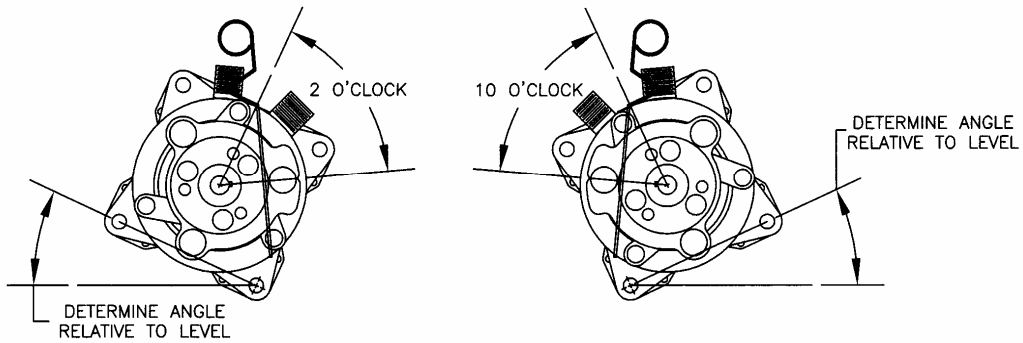

COMPRESSOR LEVEL

ANGLE	ACCEPTABLE OIL LEVEL	
	mm	INCHES
0	9 - 15	.35 - .59
10	12 - 18	.47 - .71
20	15 - 21	.59 - .83
30	18 - 24	.71 - .94

TABLE 1.



ZEE Systems, Inc.

SERVICE BULLETIN R134-06

NOTE

THE COMPRESSOR IS SHIPPED WITH THE VALVES IN THE FRONT SEAT POSITION. PRIOR TO SYSTEM START UP, MAKE SURE THE BACK SEAT VALVES ON THE COMPRESSOR ARE FULLY IN THE BACK SEAT POSITION. OPERATING SYSTEM WITH THE VALVES IN THE WRONG POSITION MAY DAMAGE THE COMPRESSOR AND VOID THE WARRANTY.

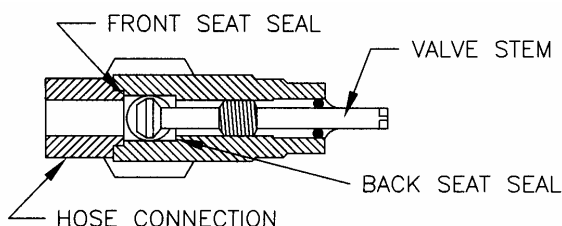

TURN VALVE STEM ALL THE WAY IN (CLOCKWISE) TO SHUT OFF CONNECTING LINE. THIS IS "FRONT SEATING". THIS ISOLATES THE REFRIGERANT FROM THE COMPRESSOR. TURN VALVE STEM ALL THE WAY OUT (COUNTER-CLOCKWISE) FOR NORMAL OPERATION. THIS IS "BACK SEATING". THIS ALLOWS FULL FLOW THROUGH THE VALVE.

NOTE

PAG OIL ABSORBS MOISTURE VERY QUICKLY. NEVER LEAVE THE SYSTEM OR OIL CONTAINER EXPOSED TO AIR FOR PROLONGED TIME. TIGHTLY RESEAL THE OIL CONTAINER AND SYSTEM AFTER EXPOSING THE OIL TO AIR. ANYTIME THE SYSTEM HAS BEEN OPENED EVACUATE AT A DEEP VACUUM FOR AT LEAST 1 (ONE) HOUR.

9.2.2 Install the modified Evaporator Assembly in the aircraft.

9.2.2.1 Add 3 oz. of PAG-100 oil to evaporator coil on the SZ78-001 Evaporator prior to installation. Add the oil through the inlet (top) or exhaust (bottom) header tubes.

9.2.3 Install the SZ41-016 Modulator Valve, 7-8159A Receiver Dryer and plumbing components.

9.2.3.1 Add 1 oz. of PAG-100 oil in the Z20012000TT4200 Hose Assembly.

NOTE

TAKE CARE NOT TO DAMAGE THE O-RING SEALS ON THE HOSE ASSEMBLIES.

NOTE

NOTE THE SZ41-016 MODULATOR VALVE AND 7-8159A RECEIVER DRYER ARE FLOW SENSITIVE. BE SURE TO NOTE THE PROPER FLOW DIRECTION DURING INSTALLATION.

9.3 When all of the plumbing connections are secure check the system for leaks. Repair as necessary.

9.4 Service the system with refrigerant as follows.



ZEE Systems, Inc.

SERVICE BULLETIN R134-06

NOTE

NEVER INVERT THE REFRIGERANT BOTTLE WHEN SERVICING OR CHARGING THE SYSTEM. LIQUID REFRIGERANT WILL DAMAGE THE COMPRESSOR.

NOTE

ANYTIME THE SYSTEM HAS BEEN OPEN TO AMBIENT CONDITIONS OR YOU SUSPECT THE SYSTEM HAS BEEN CONTAMINATED WITH AIR OR MOISTURE REPLACE THE RECEIVER-DRYER BEFORE YOU EVACUATE THE SYSTEM.

NOTE

USE ONLY VIRGIN REFRIGERANT IN THIS SYSTEM. DO NOT RETURN REMOVED REFRIGERANT TO THIS SYSTEM.

NOTE

DO NOT ADD OIL WITH THE REFRIGERANT. ONLY ADD OIL TO THE CRANKCASE OF THE COMPRESSOR DURING REGULAR SERVICE AFTER INSTALLATION.

NOTE

SEE SECTION 9.8 FOR "TOPPING OFF" PROCEDURES.

NOTE

SYSTEMS THAT ARE NOT COOLING AFTER A TOPPING OFF CHARGE MAY HAVE DEFECTIVE PARTS. REFER TO CMM FOR TROUBLE SHOOTING PROCEDURES.

NOTE

WITH R-134a REFRIGERANT THE BUBBLES DO NOT CLEAR IN THE SIGHT GLASS LIKE R-12. DO NOT ATTEMPT TO USE THIS METHOD TO DETERMINE IF THE SYSTEM IS ADEQUATELY CHARGED.

9.4.1 Evacuate the system as follows.

9.4.1.1 Attach the manifold gauges to the 1) Vacuum pump (yellow hose), 2) discharge (high side) service port (red hose), 3) the suction (low side) service port (blue hose). Make sure all valves are closed.

9.4.1.2 Pull a deep vacuum for at least 4 hours. Follow the vacuum pump manufacturer recommendations and procedures for pump operation.

9.4.1.3 When the vacuum pump is running open the 1) valve on the yellow hose (if it has one) to the vacuum pump, 2) high side (red) valve on the manifold gauges and 3) low side (blue) valve on the manifold gauges.

9.4.1.4 After 30 minutes of evacuation close the high side (red) valve on the manifold gauges and the low side (blue) valve on the manifold gauges. Note the vacuum reading. The needle should not move on either gauge. Wait 5 minutes and check the readings, the vacuum reading should not move toward zero. DO NOT turn off the pump.



ZEE Systems, Inc.

SERVICE BULLETIN R134-06

9.4.1.4.1 If the needle has moved toward zero there is a leak in the system. Stop the procedure and repair all leaks. After all leaks have been repaired start the evacuation procedure over with Step 9.4.1.1.

9.4.1.4.2 If the needle did not move open the valves and continue with the evacuation.

9.4.1.5 Continue to evacuate for at least 4 hours after Step 9.4.1.4.2. NOTE: BEFORE you turn off the vacuum pump close all valves (red and blue on the gauge set and any on the yellow hose)

9.5 Introduce a static charge of refrigerant to the system. Refer to the aircraft to aircraft maintenance manual for the amount of refrigerant to be added for that aircraft. If there is not an established amount of refrigerant refer to section 9.6.

9.5.1 Attach the manifold gauges to the 1) refrigerant bottle (yellow hose), 2) discharge (high side) service port (red hose), 3) the suction (low side) service port (blue hose). Make sure all valves are closed.

9.5.1.1 Bleed the hose (yellow) from the refrigerant bottle to the manifold gauge set to remove all air. Place the refrigerant bottle on the scale.

9.5.2 Weigh the refrigerant bottle.

9.5.3 With air conditioning system OFF. Introduce a static charge into the system. NEVER LIQUID CHARGE THE SYSTEM.

9.5.3.1 Open the valve on the refrigerant bottle.

9.5.3.2 Open high side valve (red) on the manifold gauge set.

9.5.3.3 Open the low side valve (blue) on the manifold gauge set.

9.5.3.3.1 Continue to introduce refrigerant until both the high side and low side gauges stabilize and are reading the same OR the if the system has an established target weight DO NOT exceed the target weight. When the target weight is achieved charging is complete.

9.5.3.3.2 Close both the high side and low side valves on the manifold gauge set.

9.6 Turn the air conditioning system on to introduce a running charge.

9.6.1 Place the thermometer so you are reading the temperature of the air as it enters the condensing coil (just before the fan blades).

9.6.2 Turn the system ON. Record the temperature of the air entering the condensing coil.

9.6.2.1 Add 25°F (14°C) to the temperature reading for the target condensing temperature.

EXAMPLE 1: (air temp entering coil 93°F) $93 + 25 = 118\text{F}$
(air temp entering coil 34°C) $34 + 14 = 48\text{C}$

9.6.2.1 Using the Temperature-Pressure Chart (See TABLE 2.) read the corresponding (R-134a) pressure for temperature calculated in Example 1.

EXAMPLE 2: $118\text{F} \Rightarrow 166 \text{ psig}$



ZEE Systems, Inc.

SERVICE BULLETIN R134-06

9.6.3 METHOD TO PERFORM RUNNING CHARGE OF A SYSTEM WITH KNOWN TARGET WEIGHT.

If a maximum charge weight (target weight) has been established charge using steps 9.6.3.1 and 9.6.3.2.

9.6.3.1 To charge, slowly open the low side (blue) valve on the manifold gauge set until the low side maximum reading is 40 psig. **NOTE:** NEVER OPEN THE HIGH SIDE VALVE WHILE THE SYSTEM IS RUNNING.

9.6.3.2 Continue to charge until you reach the target weight. **NOTE:** THE TARGET WEIGHT INCLUDES THE AMOUNT OF REFRIGERANT INTRODUCED DURING STATIC CHARGE PLUS THE AMOUNT INTRODUCED DURING THE RUNNING CHARGE. When the target weight is achieved close all valves. The Suction (low side) should be 30 psig \pm 7 psig. Charging is complete.

9.7 **METHOD TO DETERMINE A TARGET WEIGHT:** Calculate a target high side target pressure using Steps C.,1, C.,2, C.,3, C.,4 (see Example 1 and Example 2).

9.7.1 To charge, slowly open the low side (blue) valve on the manifold gauge set until the low side maximum reading is 40 psig. **NOTE:** NEVER OPEN THE HIGH SIDE VALVE WHILE THE SYSTEM IS RUNNING.

9.7.2 Continue to charge until you reach the calculated discharge (high side) pressure. When the target pressure is achieved close all valves. The Suction (low side) should be 30 psig \pm 7 psig. Charging is complete.

9.7.3 When charging is complete weigh the bottle and determine weight of the refrigerant charge introduced into the system. (Starting weight)-(end weight) = (total charge weight) This would be your target weight for a dry system. **NOTE:** THE TARGET WEIGHT INCLUDES THE AMOUNT OR REFRIGERANT INTRODUCED DURING STATIC CHARGE PLUS THE AMOUNT INTRODUCED DURING THE RUNNING CHARGE.

9.8 To top off an existing system:

9.8.1 Place the thermometer so you are reading the temperature of the air as it enters the condensing coil (just before the fan blades).

9.8.2 Turn the system ON. Record the temperature of the air entering the condensing coil.

9.8.3 Add 25°F (14°C) to the temperature reading for the target condensing temperature.

EXAMPLE 1: (air temp entering coil 93°F) $93 + 25 = 118\text{F}$
(air temp entering coil 34°C) $34 + 14 = 48\text{C}$

9.8.4 Using the Temperature-Pressure Chart (See TABLE 2) read the corresponding (R-134a) pressure for temperature calculated in Example 1.

EXAMPLE 2: 118°F (48°C) =>166 psig.

9.8.5 Continue to charge until you reach the calculated discharge (high side) pressure. When the target pressure is achieved close all valves. The Suction (low side) should be 30 psig \pm 7 psig. Charging is complete.



ZEE Systems, Inc.

SERVICE BULLETIN R134-06

TEMPERATURE - PRESSURE CHART

TEMP		PRESSURE (PSIG)	TEMP		PRESSURE (PSIG)
F°	C°	R-134a	F°	C°	R-134a
50	10	45.5	100	37.8	124.3
52		47.7	102		128.5
54		50.1	104		132.9
56		52.3	106		137.3
58		55.0	108		142.8
60	15.6	57.5	110	43.3	146.5
62		60.1	112		151.3
64		62.7	114		156.1
66		65.5	116		161.1
68		68.6	118		166.1
70	21.1	71.2	120	48.9	171.3
72		74.2	122		176.6
74		77.2	124		182.0
76		80.3	126		187.5
78		83.5	128		193.1
80	26.7	86.8	130	54.4	198.9
82		90.2	132		204.7
84		93.6	134		210.7
86		97.1	136		216.8
88		100.7	138		223.0
90	32.2	104.4	140	60	229.4
92		108.2	142		235.8
94		112.1	144		242.4
96		116.1	146		249.2
98		120.1	148		256.0
			150	65.6	263.0

TABLE 2.

10.0 TESTING: Refer to individual component maintenance manuals for instructions on testing the MCC and Evaporator Assembly tests.

10.1 Prior to initial system start up and every 25 HRS for the first 200 HRS of operation check the oil level in the compressor. Close the back seat valves prior to removing the oil fill plug. Service the compressor with oil as necessary. Open the back seat valves prior to operating the system.

NOTE

PAG OIL ABSORBS MOISTURE VERY QUICKLY. NEVER LEAVE THE SYSTEM OR OIL CONTAINER EXPOSED TO AIR FOR PROLONGED TIME. TIGHTLY RESEAL THE OIL CONTAINER AND SYSTEM AFTER EXPOSING THE OIL TO AIR. ANYTIME THE SYSTEM HAS BEEN OPENED EVACUATE AT A DEEP VACUUM FOR AT LEAST 1 (ONE) HOUR.



ZEE Systems, Inc.

SERVICE BULLETIN R134-06

10.2 Field testing that may be required is to check for leaks.

10.3 Electrical operation of the MCC may be tested prior to system start up.

10.3.1 To check the SZ58-003 Motor and SZ65-800 Power Condenser Fan, attach main power wires to the Motor on the MCC. Apply power, the motor and fan should start and run normally.

10.3.2 To check to compressor clutch you will need to by pass the Z99-032 High/Low Pressure Switch. Remove COIL (+) wire from C post on the terminal block. Apply 28 VDC to COIL (+) wire with any ground. The clutch should pull in with an audible click. After test return wire COIL (+) to C post of the terminal block.

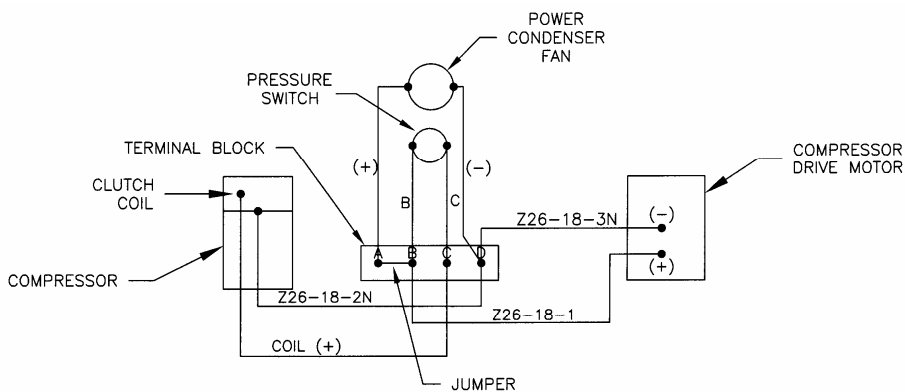

WIRING DIAGRAM 1.

CAUTION

DO NOT CHECK THE CLUTCH OPEERATION BY APPLYING POWER DIRECTLY TO POST C ON THE TERMINAL BLOCK. DAMAGE TO WIRING MAY OCCUR AS A BACK FEED MAY TRY TO ENERGIZE THE COMPRESSOR DRIVE MOTOR.

11.0 MAINTENANCE SCHEDULES:

EVERY 25 HRS for the First 100 HRS of operation	Check oil level in the compressor.
EVERY 100 HRS	Check oil level in the compressor.
EVERY 500 HRS	Check brushes in the SZ58-003-1 Motor Check Belt for wear and proper tension.
EVERY 1500 HRS	Overhaul SZ58-003-1 Motor.

14.0 REFERENCE MATERIAL: Refer to CMM SZ83-001-1B, Motor Compressor Condenser Assembly, CMM SZ78-001, Evaporator Assembly, CMM Z26-8900 Motor Compressor Assembly for basic service and maintenance instructions.



ZEE Systems, Inc.

SERVICE BULLETIN R134-06

15.0 MATERIAL COST AND AVAILABILITY: Contact ZEE Systems, Inc. for pricing and availability. Cost will vary with the condition of the MCC and Evaporator to be modified.

ZEE SYSTEM, Inc.
406 W. Rhapsody
San Antonio, TX 78216

TEL: 800-988-COOL(2665) or 210-342-9761
FAX: 210-341-2609
e-mail: info@zeeco-zeesys.com
www.zeeco-zeesys.com

15.1 Order Kit P/N: R134-06-1 for additional required components.

<i>QTY</i>	<i>Part Number</i>	<i>Description</i>	<i>Old Part Number - Disposition</i>
1ea	7-8159A	Receiver Dryer	7-8159 – Discard
1ea	SZ41-016-10.75C	Modulator Valve	SZ41-016 – Discard
1ea	Z2006AA3990	Hose Assy	Z1006000A3990 – Discard
1ea	Z20012000TT4200	Hose Assy	Z10012000E4200 – Discard
1ea	Z2006120BC220	Hose Assy	Z1006120FO190 – Discard

Note: Hose Assemblies include the O-Rings. For replacements use the following O-Rings on Hose Assy fittings,

No. 6 use MS28775-011

No. 8 use MS28775-013

No. 10 use MS28775-015