



ZEE Systems, Inc.

COMPONENT MAINTENANCE MANUAL Z26-89600

Component

Maintenance

Manual

with

Illustrated Parts List

for

***Z26-89600-Series
Motor-Compressor-
Condenser Assembly***

Includes sub-assemblies

Z26-8900-Series Motor-Compressor Assembly

SZ43-600-Series Power Condenser Assembly

Z09-600-Series Power Condenser Assembly

Z12-601-Series Power Condenser Assembly

Z14-601-Series Power Condenser Assembly

Z33-601-Series Power Condenser Assembly



ZEE Systems, Inc.

COMPONENT MAINTENANCE MANUAL Z26-89600

Record of Revisions

<i>REVISION NO:</i>	<i>ISSUE DATE</i>	<i>POSTED DATE</i>	<i>INSERTED BY:</i>
1	10-14-05	10-14-05	ZEE Systems, Inc.
2	1-3-08	1-03-08	ZEE Systems, Inc.
3	10-20-08	10-20-08	ZEE Systems, Inc.
4	2-6-12	2-6-12	ZEE Systems, Inc.
5	4-20-12	4-20-12	ZEE Systems, Inc.
6	29 SEP 2023	29 SEP 2023	ZEE Systems, Inc.
7	21 NOV 2023	21 NOV 2023	ZEE Systems, Inc.
8	17 MAY 2024	17 MAY 2024	ZEE Systems, Inc.
9	04 MAY 2026	04 MAY 2026	ZEE Systems, Inc.



ZEE Systems, Inc.

COMPONENT MAINTENANCE MANUAL Z26-89600

**List of Effective Pages
and
Table of Contents**

PAGE	TITLE	EFFECTIVE DATE / REV ##
1	COVER PAGE	2-6-12 4
2	RECORD OF REVISIONS	2-6-12 4
3	LIST OF EFFECTIVE PAGES	2-6-12 4
4	.continued	2-6-12 4
5	1.0 INTRODUCTION	1-3-08 2
	1.1 THEORY OF OPERATION	
	1.2 INSTALLATION	
	2.0 SPECIAL TOOLS AND EQUIPMENT	
	2.1 TOOLS	
6	2.2 MATERIALS	1-3-08 2
7	3.0 REPAIR AND REPLACEMENT OF COMPONENTS	1-3-08 2
8	ILLUSTRATION 1.	1-3-08 2
	3.1 DRIVE BELT	
9	3.2 COMPRESSOR	
	ILLUSTRATION 2.	1-3-08 2
10	ILLUSTRATION 3.	1-3-08 2
	ILLUSTRATION 4.	
	TABLE 1.	
11	3.3 MOTOR, COMPRESSOR DRIVE	1-3-08 2
12	3.4 POWER CONDENSER ASSEMBLY	1-3-08 2
13	3.5 WIRING	
	WIRING DIAGRAM 1 & 2 & 3	1-3-08 2
14	4.0 SERVICING – REFRIGERANT CHARGE	1-3-08 2
	5.0 SERVICE SCHEDULES	1-3-08 2
	5.1 MAINTENANCE SCHEDULES	
15	6.0 TOLERANCES	1-3-08 2
	6.1 COMPRESSOR OIL	
	6.2 CLUTCH	
	6.3 REFRIGERANT CHARGE	
	6.4 BRUSH LENGTH	
	6.5 TORQUE VALUES	
16	7.0 TROUBLE SHOOTING	1-3-08 2
	. continued	
17	8.0 ILLUSTRATED PARTS LIST	1-3-08 2
	8.1 EXPLANATION OF SYMBOLS	
18	8.2 IPL Z26-89600 MOTOR COMPRESSOR CONDENSER ASSY	5-17-24 8
19	.continued	5-17-24 8
20	.continued	5-17-24 8
21	FIGURE 1	2-6-12 4
22	8.3 IPL Z26-8900 MOTOR COMPRESSOR ASSY	1-3-08 2
23	. continued	4-20-12 5



ZEE Systems, Inc.

COMPONENT MAINTENANCE MANUAL Z26-89600

PAGE	TITLE	EFFECTIVE DATE / REV	
24	FIGURE 2	1-3-08	2
25	FIGURE 3	1-3-08	2
26	FIGURE 4	1-3-08	2
27	FIGURE 5	1-3-08	2
28	8.4 IPL Z09 & SZ43 & Z12 & Z14 POWER CONDENSER ASSY	2-6-12	4
29	.continued	4-20-12	5
30	FIGURE 6	1-3-08	2
31	9.0 SUMMARY OF MODIFICATIONS	2-6-12	4
	9.1 MOD A		
	9.2 MOD B		
	9.3 MOD C		
	9.4 MOD D	10-20-08	3
	9.5 MOD E	10-20-08	3
	9.6 MOD F	2-6-12	4
	9.7 MOD G	4-20-12	5
	9.8 MOD H	4-20-12	5
	9.9 MOD I – NOT USED	9-29-23	6
	9.10 MOD J	11-21-23	7
	9.11 MOD K	5-17-24	8
	NOTES 1/2/3	4-20-12	5
	NOTES 4/5	5-17-24	8

* INTITIAL RELEASE 9-26-05

DATE and EFFECTIVE REV originally revised.

Latest revision noted with vertical bar in the right column. |



ZEE Systems, Inc.

COMPONENT MAINTENANCE MANUAL Z26-89600

1.0 INTRODUCTION

1.0.1 This Component Maintenance Manual provides information on the maintenance, maintenance schedules and repair and replacement of parts.

1.0.2 Refer to the Illustrated Parts List (IPL) in Section 5 when using this manual or ordering replacement parts. Parts are identified in parenthesis (FIG-ITEM NO.).

1.0.3 This MCC is part of a vapor cycle air conditioning system. The refrigerant is R-134a (HFC-134a).

1.1 THEORY OF OPERATION Refrigerant is compressed into a high-pressure vapor in the electric motor driven compressor. The refrigerant moves to the condenser where air is forced over the coils. As the gas is cooled heat is released and the refrigerant condenses into a high-pressure liquid and travels to the evaporators. At the evaporators the liquid passes through a thermostatic expansion valve and becomes a low-pressure liquid which, as it passes through the coil, absorbs heat from the cabin and evaporates the refrigerant into a low pressure gas and returns to the compressor for the cycle to begin again.

NOTE

Changes for this revision are noted with a vertical bar in the RIGHT column

1.2 INSTALLATION

1.2.1 The unit should be installed with the maximum discharge duct size to and from the condenser. It is recommended that a minimum opening area of 80 free square inches be provided into the compartment where the unit is mounted and a minimum of 80 free square inches of duct area from the condenser air discharge. The importance of the minimum opening dimensions cannot be overemphasized.

1.2.2 Mounting structures and electrical circuits should be properly engineered to provide adequate current with proper overload protection and structured safety. Refer to AC 43-13-1B guidance.

1.2.3 In some installations the compressor is equipped with back seating shut off valves. If the MCC has back seating valves on the compressor, always check the position of the stem prior to operating the unit. The unit should be run with the valve in the back seat position (stem full counterclockwise, out) ONLY. Refer to the *Illustration 1*. for back seat valve operation.

NOTE

UNITS ARE SHIPPED WITH THE BACK SEAT VALVE IN THE FRONT SEAT POSITION TO PREVENT OIL LEAKAGE DURING TRANSIT. ALWAYS PLACE THE VALVE IN THE BACK SEAT POSITION AND REPLACE THE SEAL CAP PRIOR TO OPERATION. IMPROPER VALVE POSITION COULD CAUSE DAMAGE TO THE COMPRESSOR. SEE ILLUSTRATION 1.

2.0 SPECIAL TOOLS AND EQUIPMENT

2.1 TOOLS: The following special tools are required to perform the maintenance described in this manual.



ZEE Systems, Inc.

COMPONENT MAINTENANCE MANUAL Z26-89600

ITEM	SOURCE
Dip, Stick, Compressor Oil	Refer to <i>Illustration 2</i> .
Belt deflection gauge.	Commercially available.
14 mm socket	Commercially Available.
17 mm wrenches/sockets	Commercially Available.
Feeler Gauges.	Commercially Available.
External Snap Ring Pliers.	Commercially Available.
External Snap Ring Pliers.	Commercially Available.
Spanner wrench.	Commercially Available.
Graduated Cylinder.	Commercially Available.
Leak Detector, for HFC-134a	Commercially Available.
Comb Set, Fin.	Commercially Available.
Power Supply capable of 28VDC, 50 Amps	Commercially Available.
Refrigerant Recovery/Recycle equipment meeting SAE J1990 or J2209 specifications.	Commercially Available.
Manifold Gauge Set, R-134a, with automotive service connections.	Commercially Available.
Refrigeration Vacuum Pump.	Commercially Available.
Scale with 0.1 lb. increments (minimum).	Commercially Available.

2.1.2 Refer to applicable ZEE SYSTEMS Service Letter(s) for any additional special tools which may be required to service the air conditioning system.

2.2 MATERIALS: The following material may be required to perform maintenance described in this manual.

ITEM	SOURCE
MS20995C25 Lock Wire	Commercially Available.
Refrigerant, HFC-134a	Commercially Available.



ZEE Systems, Inc.

COMPONENT MAINTENANCE MANUAL Z26-89600

NOTE:

Always use virgin refrigerant. DO NOT use recovered refrigerant when servicing system.

PAG Lubricant, Refrigeration (HFC-134a)
Sanden SP-20 (PAG) or PAG-100
MOPAR 82300349 (PAG)

Commercially Available.
Commercially Available
Commercially Available

NOTE:

PAG oil absorbs atmospheric moisture very quickly. Never leave the compressor or oil container exposed to air for prolonged time. Tightly reseal the oil container and compressor immediately after exposing the oil to air.

Liquid Detergent, water soluble

Commercially available.

Cloth, lint free

Commercially available.

Tape, Insulation,

Commercially available.

3.0 REPAIR AND REPLACEMENT OF COMPONENTS. It may be necessary to remove the Z26-89600 Motor Compressor Condenser (MCC) Assembly or the Z26-8900 Motor Compressor Assembly from the aircraft to perform the inspections or maintenance described in this manual. Refer to appropriate aircraft maintenance manual for removal and installation instructions.

CAUTION

ALWAYS DISABLE THE ELECTRICAL POWER TO THE MOTOR-COMPRESSOR AND POWER CONDENSER PRIOR TO SERVICE. CONSULT THE AIRPLANE SERVICE MANUAL FOR THE BEST METHOD TO DISABLE ELECTRICAL POWER, i.e. PULL CIRCUIT BREAKERS OR REMOVE CURRENT LIMITERS, ETC.

CAUTION

AIR CONDITIONING SYSTEM UNDER PRESSURE. APPROPRIATE SAFETY MEASURES SHOULD BE TAKEN WHEN SERVICING THIS EQUIPMENT. ONLY TRAINED PERSONNEL WITH APPROVED SAFETY EQUIPMENT SHOULD PERFORM SERVICING DUTIES.

NOTE

IT IS UNLAWFUL TO RELEASE R-12 OR OTHER REFRIGERANTS TO THE ATMOSPHERE. USE APPROVED RECOVERY/RECYCLE EQUIPMENT TO CAPTURE REFRIGERANTS. USE ONLY LAWFUL MEANS TO DISPOSE OF RECOVERED REFRIGERANTS. CHECK WITH LOCAL AGENCIES FOR APPROVED DISPOSAL PROCEDURES.

NOTE

CAP ALL OPEN LINES TO PREVENT CONTAMINANTS AND MOISTURE FROM ENTERING THE SYSTEM.



ZEE Systems, Inc.

COMPONENT MAINTENANCE MANUAL Z26-89600

NOTE

DUE TO THE TIGHT FIT OF THE MOTOR COMPRESSOR CONDENSER ASSY, IT MAY BE NECESSARY TO REMOVE THE MOTOR COMPRESSOR CONDENSER ASSY AND THE EVAPORATOR TO PERFORM SOME OF THE MAINTENANCE DESCRIBED BELOW.

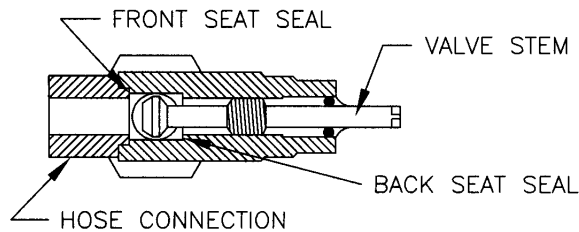

TURN VALVE STEM ALL THE WAY IN (CLOCKWISE) TO SHUT OFF CONNECTING LINE. THIS IS "FRONT SEATING". THIS ISOLATES THE REFRIGERANT FROM THE COMPRESSOR.
TURN VALVE STEM ALL THE WAY OUT (COUNTER-CLOCKWISE) FOR NORMAL OPERATION. THIS IS "BACK SEATING". THIS ALLOWS FULL FLOW THROUGH THE VALVE.

ILLUSTRATION 1.

3.1 DRIVE BELT (4-20/-21) It may be necessary to remove the Z26-8900 Motor Compressor (MC) Assembly from the Z26-89600 Motor Compressor Condenser Assembly to change belts.

3.1.1 REMOVAL. Extreme care should be taken during maintenance not to strike or use pullers directly against the hardened (black or grey) area of these pulleys as this may crack or chip the anodized surface. To remove the belt, break the lock wire on the turnbuckle (2-15/-34) and back off the jam nuts (2-40/-41). The groove on the turnbuckle indicates the end with the left-hand thread. Loosen the hardware (2-19/-32/-38) on the clevis (2-7) that attaches to the bracket on the motor and the rod end hardware (2-6/-26/-32/-38) that attaches to the compressor. Loosen the 17 mm nut (3-43) on the 10 mm bolt (3-44) that secures the compressor to the angles (4-11/-12). You will need two 17 mm wrenching tools. Loosen the belt tension by turning the turnbuckle to bring the pulleys closer together. When the belt is loose slide it off of the large compressor pulley (3-18) then the small motor pulley (2-4/-4).

3.1.2 INSPECTION: Inspect the belt for deterioration, damage and fraying. Replace defective belt.

3.1.4 INSTALLATION: Always place the belt over the smaller diameter pulley first then carefully slide the belt over the larger diameter pulley. Care should be taken to not tear the edges of the belts.

3.1.5 BELT ADJUSTMENT: With the belt in place turn the turnbuckle (2-15/-34) until a tension with a deflection of .12-.18 the belt midway between pulleys with 3-4 pound pull is achieved. Tighten the 17 mm nut (3-43) that secures the compressor bolt (3-44) to torque of 30 foot-pounds. Secure the jam nuts (2-40/-41) and secure with lock wire. Tighten the hardware that attaches the clevis (2-29/-32/38) to the motor and rod end (2-26/-32/38) to the compressor bracket.

3.1.5.1 Check the belt alignment before running the motor. Turn the compressor pulley by hand to see that the belt is properly aligned. Slight striking of the belt against the rim on the small pulleys is normal but not to the point where chafing occurs. Readjust belt if necessary. Next run the motor and check for smooth operation. If a belt hops or flutters it is too loose. If the belt is too tight against the pulley rim a discharge of fine dust like rubber particles will occur. Check the condition of the smaller pulley rim and readjust belts as necessary. Secure the turnbuckle jam nuts with .025 lock wire. Once the belts are adjusted and all of the



ZEE Systems, Inc.

COMPONENT MAINTENANCE MANUAL Z26-89600

hardware is properly tightened no further adjustments should be necessary if the components are not disturbed.

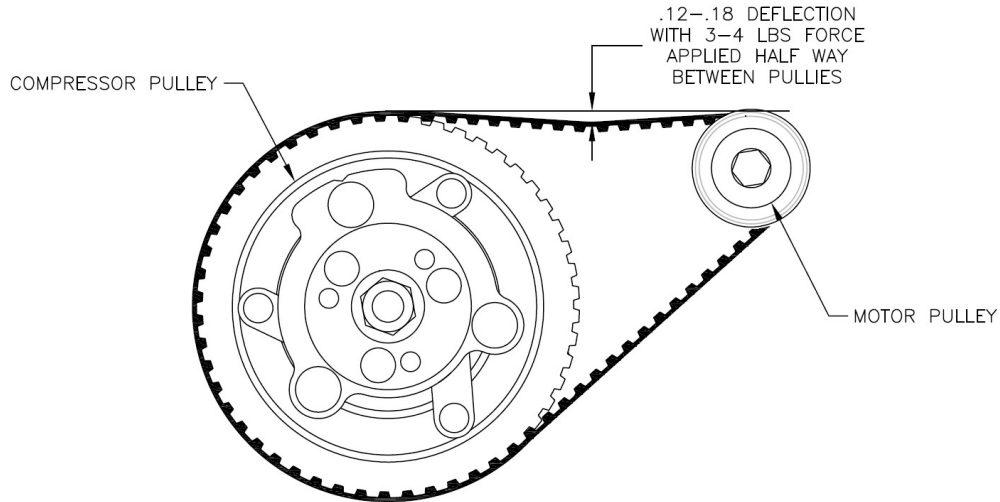

ILLUSTRATION 2.

3.2 **COMPRESSOR (3-19)** It is necessary to remove the compressor pulley (3-18) to remove the compressor from the mounting angles. Take care not to damage or lose the shims and key on the compressor shaft.

3.2.1 **REMOVAL:** If the system has back seat valves close move the valve stem to the front seat position to isolate the refrigerant from the compressor, then remove the back seat valves from the compressor.

3.2.1.1 Disconnect the electrical connections to the terminal block or motor for the clutch.

3.2.1.2 Remove the belt as described in 3.1. Remove the bolt that secures the rod end on the turnbuckle.

3.2.1.3 Hold the compressor pulley stationary while removing the 14 mm (2-23) retaining nut. Remove the internal snap ring (not shown) just under the nut. Now you can slide the clutch plate (2-16) out. Now slide the pulley (3-18) off the compressor. Take care not to damage or lose the key or shims (not shown).

3.2.1.4 Loosen and remove the 17 mm (3-42) nut that secures the 10 mm bolt (3-44). Remove the 10 mm bolt and spacers (3-9/-10). The compressor can now be removed from the angles.

3.2.2 **INSPECTION:** Check for signs of oil leakage around the fittings.

3.2.2.1 Check oil level of new system installation. Fashion an oil dipstick from any soft metal bar as shown in *Illustration 1*. Determine the angle of the compressor from horizontal as shown in *Illustration 2*. Remove the oil fill plug on top of the compressor, take care not to damage the seal. Place the dipstick in the opening; make sure the dip stick goes in past the crankshaft and pistons. Refer to TABLE 1. for correct oil level and add oil as necessary. Return and tighten oil fill plug.



ZEE Systems, Inc.

COMPONENT MAINTENANCE MANUAL Z26-89600

3.2.2.2 Check oil level of existing system. If you are replacing a failed compressor from an existing installation drain the oil from the defective compressor and record the amount. Drain the oil from the new replacement compressor. Add back the same amount of oil to the new replacement compressor that was removed from the defective compressor.

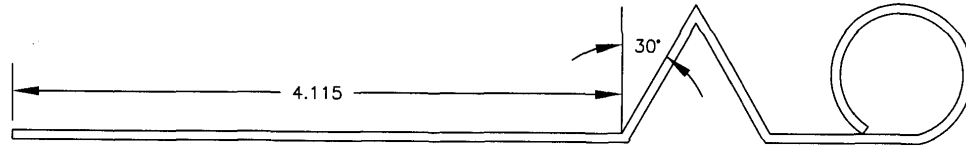

Dip Stick
ILLUSTRATION 3.

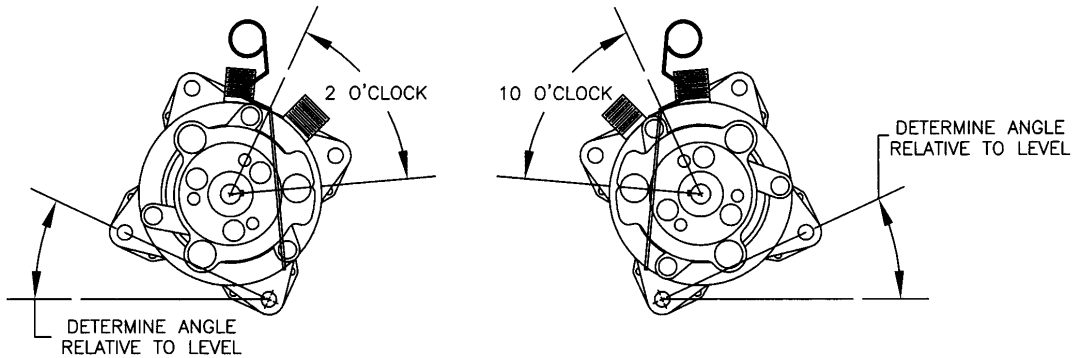

Determine the angle of the compressor relative to horizontal.

ILLUSTRATION 4.

ANGLE	ACCEPTABLE OIL LEVEL	
	mm	INCHES
0	9 - 15	.35 - .59
10	12 - 18	.47 - .71
20	15 - 21	.59 - .83
30	18 - 24	.71 - .94

TABLE 1.

3.2.5 INSTALLATION: With the compressor pulley removed, align the compressor and spacers (3-9/-10) with angles (4-11/-12) and slide the 10 mm x 150 mm bolt (3-44) into position. Do not forget the flat washer (3-42) under bolt head before inserting. Make sure the bolt head is on the pulley side. Tighten the 17 mm nut just enough to secure the compressor but loose enough to adjust the belt.

3.2.5.1 Slide the compressor pulley (3-18) assembly on the compressor.



ZEE Systems, Inc.

COMPONENT MAINTENANCE MANUAL Z26-89600

3.2.5.2 Align the keyway and place the clutch plate (2-16) on the compressor shaft. Install the internal snap ring. Replace the 14 mm (2-23) retaining nut and torque to 11-15 lb-ft (15-21 N-m)

3.2.5.3 Check the air gap with the feeler gauge that a clearance of .016" - .031" (0.4 – 0.8mm). If the gap is not even around the clutch, gently tap down at the high spots. If the overall air gap is out of specification remove the clutch plate and add or subtract shims as necessary.

3.2.5.4 Remove the bracket (2-14) from the defective compressor and attach the bracket to the replacement compressor.

3.2.5.5 Attach the rod end (2-6) of the turnbuckle to the bracket (2-14) on the compressor. Do not fully tighten at this time.

3.2.5.6 Attach and adjust the belt as described in Section 3.1 through 3.1.6.

3.2.5.7 Check the operation of the clutch plate (2-16) and coil (2-17). DO NOT apply power directly across pins C and D on the terminal block. Remove the (+) wire from the compressor coil at pin C on terminal block. Apply 28 VDC across the compressor coil (+) wire and pin D (-) on the terminal block. The clutch should pull into the pulley. Remove power and the clutch should release (move away) and the pulley will be free. Connect the coil (+) wire back to pin C on the terminal block. Refer to Wiring Diagram 1 for schematic.

3.3 MOTOR, COMPRESSOR DRIVE (2/3/4-3) Prior to disassembly mark the support positions (4-5/-8) for proper alignment during reassembly. The mounting holes are not centered on the supports (4-8/-5) and the motor is not centered between the angles.

NOTE

USE ONLY THE SPECIFIED MOUNTING HARDWARE. INCORRECT BOLT LENGTH CAN CAUSE A SHORT IN THE MOTOR WINDINGS.

3.3.1 REMOVAL: Disconnect the positive and negative leads to the motor. Remove the clamp and all remaining attached wiring from the motor.

3.3.1.1 Remove and set aside the belt in accordance with paragraph 3.1.

3.3.1.2 Break the lock wire and remove the four bolts and hardware (2-30/-36/-39) that attach the supports to the angles (4-11/-12).

3.3.1.3 To remove the supports (4-5/-8) from the motor, loosen and remove the four bolts and hardware (4-25/-35/-37). Mark their position for proper reassembly.

3.3.1.4 Use a spanner wrench to hold the motor pulley (2-2/-4). Loosen and remove the bolt (4-28) and hardware (4-36/-39) spacer (4-1) and pulley. Inspect the motor pulley for damaged or rounded teeth. Replace if damaged.

3.3.2 INSPECTION: Refer to Service Letter 58-003-3 for brush inspection information.



ZEE Systems, Inc.

COMPONENT MAINTENANCE MANUAL Z26-89600

3.3.3 **INSTALLATION:** Place the motor pulley on the shaft. Make sure the flats of the pulley mate with the flats on the motor shaft. Place the spacer and hardware (4-1/-36/-39) on the end of the pulley. Using a spanner wrench hold the motor pulley and tighten the bolt (4-28).

3.3.3.1 Attach the supports (4-5/-8) and hardware (4-25/-35/-37) to the motor. Make sure they are aligned properly or the motor pulley will not be aligned with the compressor pulley. Tighten bolts and secure with lock wire.

3.3.3.2 Attach the supports (4-5/-8) and motor to the angles (4-11/-12), tighten and secure with lock wire.

3.3.3.3 Install and adjust the belt as described in section 3.1.

3.3.3.4 Attach wiring to motor. Refer to Wiring Diagram 1.

3.4 POWER CONDENSER ASSEMBLY (1-2, and FIG. 5) It may be necessary to remove the Motor Compressor Assembly from the aircraft to access the mounting screws on the Power Condenser Assembly

WARNING
THE SYSTEM IS UNDER PRESSURE. SYSTEM PRESSURE MUST BE RELIEVED BEFORE REMOVAL OF THE POWER CONDENSER ASSEMBLY.

3.4.1 **REMOVAL:** Disconnect the electrical connections from the Blower Assembly.

3.4.1.1 Disconnect the inlet hose (top) (1-8) from the Condenser Assembly (2-2). Disconnect the pressure switch adapter (1-9). You do not have to remove the pressure switch or electrical connections. Plug or cap all open connections to prevent contamination of the system. Loosen and remove the screws and washers (1-11/-13/-19) which attach the condenser assembly to the base plate (1-1/-22).

3.4.2 **INSPECTION:** Check the coil (5-2) for leaks or kinks in the tubing. Check the coil fins for debris and flattened areas which prevent air flow over the coils.

3.4.2.1 Hydrostatic test the coil to check for leaks. Remove the inlet duct and outlet duct from the coil. Plug or cap the outlet (bottom) connection. Attach a bottle of dry nitrogen with a suitable connector to the inlet (top). Submerge the coil in a clear water bath. Slowly apply 300 PSIG. No leaks or deterioration are allowed. Replace defective coil. Relieve the pressure.

3.4.3 Only minor field repairs are allowed as described below. Coil is replaced on condition. Defective coils must be replaced.

3.4.3.1 Straighten damaged or flat fins by using a fin comb to comb out the fins. Clean and remove debris from coil fins that obstruct the airflow over the coil. There is no other field repair of the condenser coil.

3.4.4 Replace defective Blower Motor Assembly (5-9). Disconnect the electrical leads and loosen and remove hardware (5-4/-7, 5-11/-12)) and remove Blower Motor Assembly from inlet duct (5-10).

3.4.5 **INSTALLATION:** Blower Motor Assembly (5-9). Install in reverse order of step 3.4.4.



ZEE Systems, Inc.

COMPONENT MAINTENANCE MANUAL Z26-89600

3.5 WIRING The Z26-89600 has circuitry to control the Condenser Power Fan, clutch and a High/Low Pressure Switch to disengage the clutch should an unsafe pressure condition exist. The circuits are connected through a Terminal Block which allows for easy replacement of components. Refer to Diagram 1, 2 or 3. for appropriate circuit schematic.

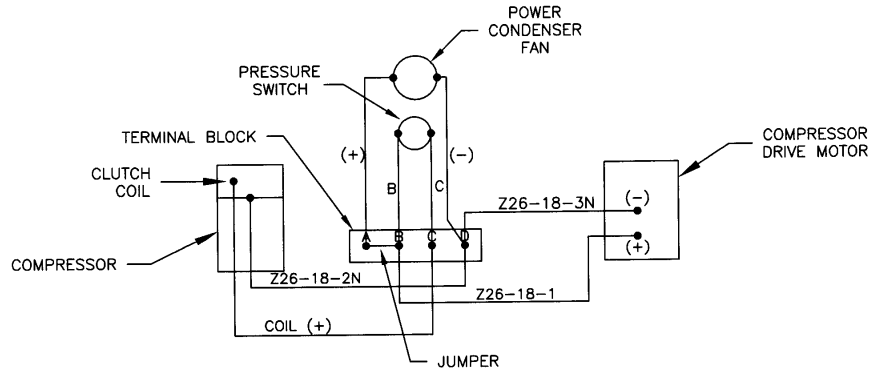

WIRING DIAGRAM 1.

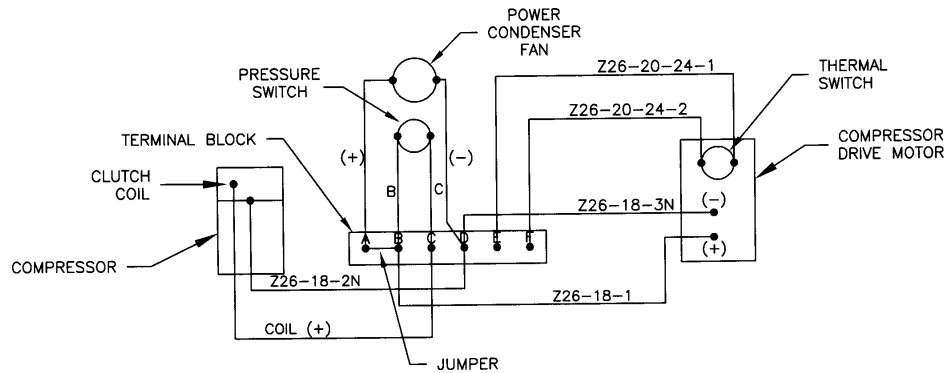

WIRING DIAGRAM 2.

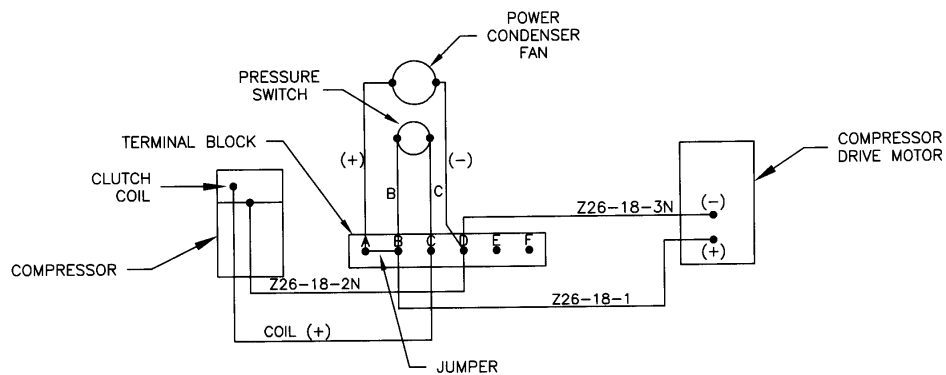

WIRING DIAGRAM 3.



ZEE Systems, Inc.

COMPONENT MAINTENANCE MANUAL Z26-89600

CAUTION

AIR CONDITIONING SYSTEM UNDER PRESSURE. APPROPRIATE SAFETY MEASURES SHOULD BE TAKEN WHEN SERVICING THIS EQUIPMENT. ONLY TRAINED PERSONNEL WITH APPROVED SAFETY EQUIPMENT SHOULD PERFORM SERVICING DUTIES.

NOTE

IT IS UNLAWFUL TO RELEASE R-12 OR OTHER REFRIGERANTS TO THE ATMOSPHERE. USE APPROVED RECOVERY/RECYCLE EQUIPMENT TO CAPTURE REFRIGERANTS. USE ONLY LAWFUL MEANS TO DISPOSE OF RECOVERED REFRIGERANTS. CHECK WITH LOCAL AGENCIES FOR APPROVED DISPOSAL PROCEDURES.

NOTE

CAP ALL OPEN LINES TO PREVENT CONTAMINANTS AND MOISTURE FROM ENTERING THE SYSTEM.

4.0 SERVICING - REFRIGERANT CHARGE

4.0.1 Refer to Aircraft maintenance manual or ZEE Systems, Inc. Service Letter Z26-1 for recommended refrigerant charging service instructions.

5.0 SERVICE SCHEDULES

5.1 MAINTENANCE SCHEDULE The maintenance and service schedules are ZEE Systems, Inc. recommended intervals. Actual operating and environmental conditions may require more frequent service.

ITEM DESCRIPTION	INSPECTION INTERVAL *	R&R/T.B.O. HRS
Z26-89600 M-C-C	EVERY 250 HRS* - INSPECT FOR LOOSE, DAMAGED ITEMS. CHECK FOR AND REMOVE ANY DEBRIS OR OBSTRUCTIONS TO THE CONDENSER COILS. CHECK FOR SIGNS OF OIL LEAKS.	2,000
Z26-8900 M-C	EVERY 250 HRS* - INSPECT FOR LOOSE, DAMAGED ITEMS. CHECK FOR SIGNS OF OIL LEAKS.	2,000/2,500#
DRIVE BELT**	EVERY 250 HRS* - INSPECT AS PER SECTION 3.1.2	1,000
SZ58-003-(ALL) Motors without MOD M		
Z6386A Brushes	EVERY 250 HRS* - INSPECT BRUSHES SECTION 3.3.2	2,000
#SZ58-003-(ALL) Motors with MOD M		
Z6386C Brushes	EVERY 250 HRS* - INSPECT BRUSHES SECTION 3.3.2	2,500



ZEE Systems, Inc.

COMPONENT MAINTENANCE MANUAL Z26-89600

ALL SZ58-003-(ALL) Motors must be returned to The Zee Company, Inc. (the Factory Authorized Repair Facility for ZEE Systems, Inc.) for Brush Change, Repair or Overhaul. Contact Derek at 210-342-9479 or repairs@zeecompanyinc.com for more information.

COMPRESSOR**	(NEW) AFTER THE FIRST 100 HOURS - INSPECT AS PER SECTION 3.2.2.1	
ITEM DESCRIPTION	INSPECTION INTERVAL *	R&R/T.B.O. HRS
	EVERY 500 HRS - INSPECT AS PER SECTION 3.2.2	2,000
POWER CONDENSER FAN	EVERY 500 HRS – INSPECT LOOSE, DAMAGED ITEMS. CHECK FOR AND REMOVE ANY DEBRIS OR OBSTRUCTIONS ON THE INLET SIDE TO THE CONDENSER COILS.	ON CONDITION

* UNIT OPERATING TIME

** COMPONENT IS PART OF THE Z26-8900 MOTOR-COMPRESSOR ASSEMBLY.

REFER TO SANDEN “SANDEN SD COMPRESSOR SERVICE MANUAL” FOR ADDITIONAL COMPRESSOR SERVICE INFORMATION.

6.0 TOLERANCES

6.1 COMPRESSOR OIL. NEW refer to *Illustration 2* and *Illustration 3* and Table 1. REPLACEMENT refer to Section 3.2.2.2.

6.2 CLUTCH. When assembled an air gap of .016” - .031” (0.4 – 0.8mm) between the pulley and clutch plate.

6.3 REFRIGERANT CHARGE. Refer to aircraft maintenance manual or ZEE Systems, Inc. Service Letter SZ43-1.

6.4 BRUSH LENGTH, COMPRESSOR DRIVE MOTOR. The minimum brush length on the drive motor is 0.750" (19mm). Refer to SIL 58-001.

6.5 TORQUE VALUES. If not specified, use standard torque values for bolts.

14 mm Pulley Nut 11-15 lb-ft (15-21 N-m)

17 mm (10 mm Compressor Bolt) Nut 30 lb-ft (42 N-m)



ZEE Systems, Inc.

COMPONENT MAINTENANCE MANUAL Z26-89600

7.0 TROUBLE SHOOTING

TROUBLE	POSSIBLE CAUSE	REMEDY
Compressor Motor trips circuit breaker.	Motor shorted.	Replace Motor.
TROUBLE	POSSIBLE CAUSE	REMEDY
	Motor brushes worn beyond limits.	Overhaul Motor.
Compressor Motor trips current limiter.	Short in wiring.	Check wiring to motor, repair as required.
Compressor Motor inoperative.	Motor open Motor brushes worn beyond limits.	Replace Motor. Overhaul Motor.
	Short in wiring.	Check wiring to motor, repair as required.
Excessive vibration at Motor/Compressor.	Improper belt tension.	Adjust belt to correct tension.
	Worn, damaged or loose or over tightened mounts.	Adjust or replace mounts.
Quick refrigerant loss.	Open in system.	Check compressor head gasket. Check Hoses or tubing for holes. Check connections. Replace defective component. Service system
	Defective O-Ring.	Replace defective O-Ring. Service system
	Loose connections.	Tighten connections. Service system
Slow refrigerant loss.	Loose connections.	Tighten connections. Service system
Low or no cooling. Low Pressures.	Incorrect Back Seat Valve position.	Place Back Seat Valve In proper position for normal operation.



ZEE Systems, Inc.

COMPONENT MAINTENANCE MANUAL Z26-89600

TROUBLE	POSSIBLE CAUSE	REMEDY
	Low refrigerant.	Service as necessary.
Compressor clutch does not engage.	Low, or high discharge pressures.	Check refrigerant charge. Service as necessary.
	Defective Pressure Switch	Replace Pressure Switch.
	Defective Coil.	Replace Coil.
	Defective wiring.	Refer to Diagram 1. Repair as necessary.
MC and Clutch start up normally. Clutch disengages after a short time.	Power Condenser Fan defective.	Replace Power Condenser Fan Assembly.

8.0 ILLUSTRATED PARTS LIST

8.1 EXPLANATION OF SYMBOLS:

ALT - The Part Number shown is an approved alternate, either part number may be used.

MOD "X" Refers to modification information of this part as applicable to this assembly.

NP - Not Procurable individually, see next higher assembly.

NS - Not Shown

OBS - Obsolete

USAGE/QTY - This identifies parts used on specific applications (not common to all units). If no code is stated the part is common to all dash numbers.

.. - Part of higher assembly.

*/# - See explanation at end of parts list. "AN", "MS" and "NAS" equivalent hardware is considered to be approved alternates for each other and may be used. The most common are as follows:

PART NUMBER	ALTERNATE	DESCRIPTION
AN345-516	MS35650-3312	NUT, MACHINE
AN364-624A	MS21083N6	LOCK NUT
AN365-428A	MS21044N4	LOCK NUT
AN365-832A	MS21044N08	LOCK NUT
AN501A10-6	MS35266-61	SCREW
AN935-416	MS35338-44	WASHER, LOCK
AN935-516	MS35338-45	WASHER, LOCK
AN935-616	MS35338-46	WASHER, LOCK
AN935-8	MS35338-42	WASHER, LOCK
AN960-416	NAS1149F0463P	WASHER, FLAT
AN960-416L	NAS1149F0432P	WASHER, FLAT
AN960-516	NAS1149F0563P	WASHER, FLAT
AN960-516L	NAS1149F0532P	WASHER, FLAT
AN960-616	NAS1149F0663P	WASHER, FLAT
AN960-616L	NAS1149F0632P	WASHER, FLAT
AN960-8L	NAS1149FN816P	WASHER, FLAT



ZEE Systems, Inc.

COMPONENT MAINTENANCE MANUAL Z26-89600

8.2 ILLUSTRATED PARTS LIST Z26-89600 MOTOR COMPRESSOR CONDENSER ASSEMBLY.

FIG-ITEM	PART NUMBER	NOMENCLATURE	QTY	USAGE MOD, NOTES CODE
1	Z26-89600-1	MOTOR COMPRESSOR CONDENSER ASSEMBLY		A
	Z26-89600-2	MOTOR COMPRESSOR CONDENSER ASSEMBLY		B
	Z26-89600-3	MOTOR COMPRESSOR CONDENSER ASSEMBLY		C
	Z26-89600-4	MOTOR COMPRESSOR CONDENSER ASSEMBLY		D
	Z26-89600-5	MOTOR COMPRESSOR CONDENSER ASSEMBLY		E
	Z26-89600-6	MOTOR COMPRESSOR CONDENSER ASSEMBLY		F
	Z26-89600-7	MOTOR COMPRESSOR CONDENSER ASSEMBLY		G
	Z26-89600-8	MOTOR COMPRESSOR CONDENSER ASSEMBLY		H
-1	Z09-406-1	BASE PLATE ASSEMBLY	1	A
	SZ43-304-1	BASE PLATE ASSEMBLY	1	B,D
	SZ45-301-1	BASE PLATE ASSEMBLY	1	C
	Z26-303-1	BASE PLATE ASSEMBLY	1	E
	SZ43-302-1	BASE PLATE ASSEMBLY	1	F
	SZ43-305-1	BASE PLATE ASSEMBLY	1	G
	SZ43-304-1A	BASE PLATE ASSEMBLY	1	B MOD G
-2	Z09-600-3	POWER CONDENSER ASSY	1	A
	Z09-600-3 (MOD A)	POWER CONDENSER ASSY	1	A MOD B
	SZ43-600-1	POWER CONDENSER ASSY	1	B,F,G
	Z33-601-1	POWER CONDENSER ASSY	1	B MOD F
	Z14-601-2	POWER CONDENSER ASSY	1	C
	SZ43-600-2	POWER CONDENSER ASSY	1	D
	Z12-601-2	POWER CONDENSER ASSY	1	E
-3	NOT USED			
-4	NOT USED			
-5	Z26-8900-1	MOTOR COMPRESSOR ASSY	1	A,B,D SEE FIG. 2 F, G
	Z26-8900-5	MOTOR COMPRESSOR ASSY	1	C SEE FIG. 2
	Z26-8900-5 (MOD A)	MOTOR COMPRESSOR ASSY	1	C
	Z26-8900-3	MOTOR COMPRESSOR ASSY	1	E



ZEE Systems, Inc.

COMPONENT MAINTENANCE MANUAL Z26-89600

FIG-ITEM	PART NUMBER	NOMENCLATURE	QTY	USAGE MOD, NOTES CODE	
	Z26-8900-1 (MOD J)	MOTOR COMPRESOR ASSY	1	B	MOD G
	Z26-8900-1 (MOD K)	MOTOR COMPRESOR ASSY	1	B	MOD H
-6	Z031-1-4	TERMINAL BLOCK	1	A,B,C,D	
	Z031-1-6	TERMINAL BLOCK	1	C	MOD A
			1	E	
NS	Z12-301-1	BUS (JUMPER)	1		SEE WIRING DIAG.1
	ALT: MS25226-2-2				
-7	Z99-032-1	PRESSURE SWITCH	1		
-8	Z2008AB103	HOSE ASSY	1	A	3
	Z2008AB83	HOSE ASSY	1	B,C	3
	Z2008175CD162	HOSE ASSY	1	B	MOD F, 2 & 3
	Z2008AX000B83	HOSE ASSY	1	D,G	3
	Z2008210BC313	HOSE ASSY	1	A,B,	MOD C, 3
				C,D	
	Z2008200BXC174	HOSE ASSY	1	E	3
	Z2018210BC313	HOSE ASSY	1		MOD E, 3
	Z2008130BC236	HOSE ASSY	1	F	3
	Z2008175CD182	HOSE ASSY	1	B	MOD G, 4
			1	B	MOD H, 4
	Z2008165BC313	HOSE ASSY	1	B	MOD J, 5
	Z2008270BC300	HOSE ASSY	1	B	MOD K, 4 & 5
-9	DS200A-6X6F	ADAPTER, SWITCH PORT	1		
-10	AN6-7A	BOLT	4		
-11	MS21083N08	NUT, LOCK	12		
	ALT: AN364-832A				
-12	MS21919WDG3	CLAMP	2		
-13	MS35206-245	SCREW	10	A,B,C,D	
			14	E	
-14	MS35338-42	WASHER, LOCK	12	A,B,C,D,	
	ALT: AN935-8		16	E	
-15	MS35338-46	WASHER, LOCK	4		
-16	N3	CLAMP	1		
-17	NAS1096-2-8	SCREW	2		
-18	NOT USED				
-19	NAS1149FN816P	WASHER, FLAT	22	A,B,C,D	
	ALT: AN960-8L		26	E	
-20	NAS1149F0663P	WASHER, FLAT	4		
	ALT: AN960-616				
-21	NOT USED				
-22	NOT USED				
-23	NOT USED				
-24	Z26-200-8	ADAPTER, B.S.V.	1		
	ALT: Z26-200-8A	ADAPTER, B.S.V.	1		
	..MS28775-013	O-RING	1		
-25	Z26-200-10	ADAPTER, B.S.V.	1		
	ALT: Z26-200-10A	ADAPTER, B.S.V.	1		
	..MS28775-015	O-RING	1		
NS	MS3367-4-9	CABLE TIE	AR		



ZEE Systems, Inc.

COMPONENT MAINTENANCE MANUAL Z26-89600

FIG-ITEM	PART NUMBER	NOMENCLATURE	QTY	USAGE MOD, NOTES CODE
NS	400649-1	I. D. PLATE	1	

MOD A This applies to the Z26-89600-3 Assembly only. When using the Z26-8900-5 (Mod. A Thermal Switch) Motor Compressor Assembly delete the Z031-1-4 Terminal Block and use the Z031-1-6 Terminal Block. Refer to Wiring Diagram 2.

MOD B This applies to the Z26-89600-1 Assembly only. Use the Z09-600-3 MOD A Power Condenser Assembly.

MOD C This applies to the Z26-89600-1/-2/-3/-4 Assemblies only. Use Hose Assembly Z2008210BC313.

MOD D Allows for using the Z26-8900-7 MC. Factory modification only.

MODE This applies to all dash numbers. Use Hose Assembly Z2018210BC313.

MOD F This applies to the Z26-89600-2 only. Use the Z33-601-1 Power Condenser Assembly. Use Hose Assembly Z2008175CD162. SEE NOTE 2 below.

MOD G is Applicable to Z26-89600-2 only. Use Z26-8900-1 with MOD J. Add SZ43-304-1A Base Plate and Z2008175CD182 Hose Assy.

MOD H Applicable to Z26-89600-2 only. Use Z26-8900-1 with MOD K.

MOD I NOT USED.

MOD J Applicable to Z26-89600-2 with MOD F only. Add Hose Assembly Z2008165BC313. Delete Z2008175CD182 and Z200175CD162.

MOD K Applicable to Z26-89600-2 with MOD F only. Add Hose Assembly Z2008270BC300. See SERVICE LETTER SL Z26-89600-3, Rev. 1.

NOTE 1 Rather assign a unique part number or modification to one-of-a-kind changes for custom applications place an "X" behind the ending dash number. The changes will be identified and recorded with the serial number.

NOTE 2 MOD F has changed. Was: use of Hose Assembly Z2008210BC236 for any dash no.

NOTE 3 Hose Assemblies which have nickel plated fittings will have an "N" at the end of the part number.

NOTE 4 Applies to Z26-89600-2 with MOD F only.

NOTE 5 Applies to Z26-89600-2 with MOD F only. Delete all previous hose assemblies, Z2008AB83, Z2008175CD162, Z2008210BC313, Z2008175CD182. See SERVICE LETTER SL Z26-89600-3, Rev. 1.



ZEE Systems, Inc.

COMPONENT MAINTENANCE MANUAL Z26-89600

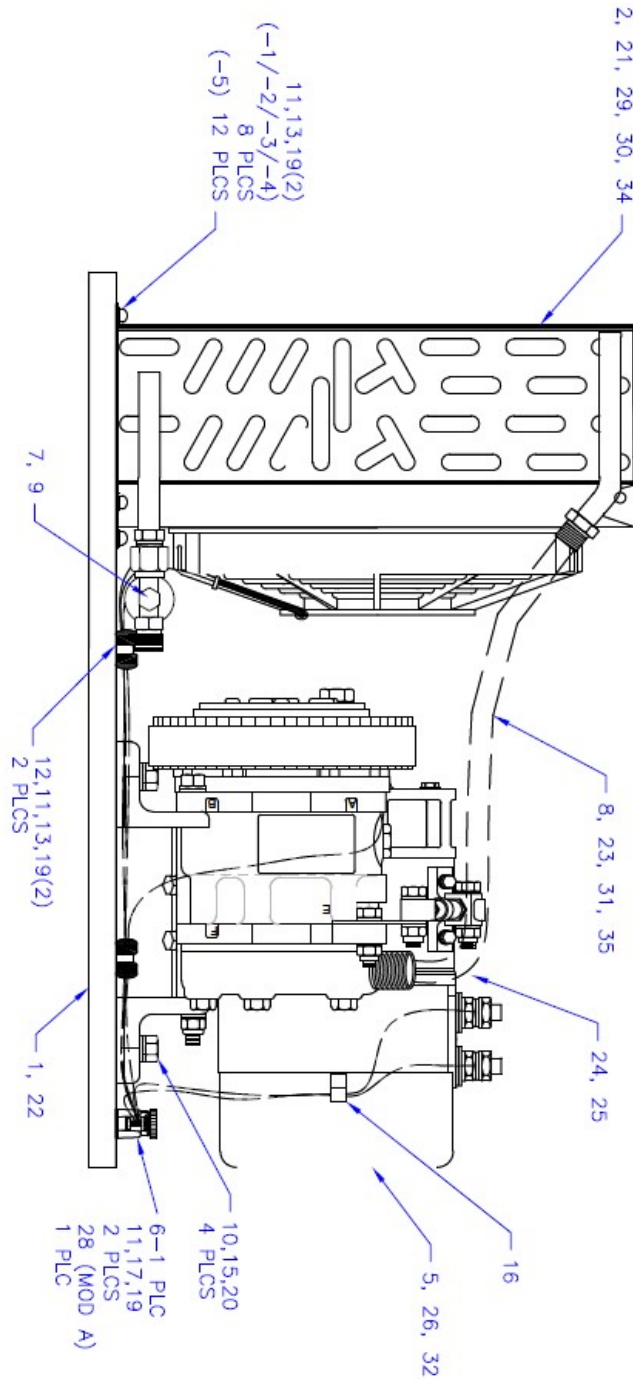

FIG. 1



ZEE Systems, Inc.

COMPONENT MAINTENANCE MANUAL Z26-89600

8.3 ILLUSTRATED PARTS LIST Z26-8900 MOTOR COMPRESSOR ASSEMBLY.

FIG-ITEM	PART NUMBER	NOMENCLATURE	QTY	USAGE MOD, NOTES CODE
2/3/4	Z26-8900-1	MOTOR COMPRESSOR ASSEMBLY		A
	Z26-8900-2	MOTOR COMPRESSOR ASSEMBLY		B
	Z26-8900-3	MOTOR COMPRESSOR ASSEMBLY		C
	Z26-8900-4	MOTOR COMPRESSOR ASSEMBLY		D
-1	SZ41-019-5	SPACER	1	
-2	SZ83-041-6	PULLEY	1	A MOD J/K/ L
	SZ43-008-3	PULLEY	1	B
-3	SZ58-003-1	MOTOR	1	
	ALT: SZ58-003-2			
-4	SZ83-041-4	PULLEY	1	C,D
-5	Z14-401-1	SUPPORT	2	
-6	Z25-404-1	CLEVIS	1	
-7	Z25-404-2	ROD END	1	
-8	Z26-400-1	SUPPORT	2	
-9	Z26-401-1	SPACER	1	
-10	Z26-401-2	SPACER	1	
-11	Z26-402-1	ANGLE	1	
-12	Z26-402-2	ANGLE	1	
-13	Z26-403-1	BRACKET	1	
-14	Z26-404-1	BRACKET	1	
-15	Z26-405-1	TURNBUCKLE BARREL	1	A,B
	Z26-405-2	TURNBUCKLE BARREL	1	A MOD J/K
-16	Z99-421-7	CLUTCH PLATE	1	
-17	Z99-421-9	COIL ASSY	1	
-18	Z99-423-1	PULLEY ASSY	1	
-19	Z99-915-4	COMPRESSOR	1	
-20	263L100	BELT	1	A MOD J/K/L/M
	255L075	BELT	1	B
-21	270L100	BELT	1	C,D
-22	400649-1	I.D. PLATE	1	
-23	8M-1.25	NUT, LOCK, METRIC	1	
-24	AN4H5A	BOLT	2	
-25	AN4H17A	BOLT	4	
-26	AN5-11A	BOLT	1	
-27	AN5-12A	BOLT	1	



ZEE Systems, Inc.

COMPONENT MAINTENANCE MANUAL Z26-89600

FIG-ITEM	PART NUMBER	NOMENCLATURE	QTY	USAGE MOD, NOTES CODE
-28	AN6-6A	BOLT	1	
-29	AN6-12A	BOLT	2	
-30	AN76A11	BOLT	4	
	ALT: MS20074-06-11			
-31	MS20995C025	LOCK WIRE	AR	
-32	MS21045-5	NUT, LOCK	2	
-33	MS21045-6	NUT, LOCK	2	
-34	MS21251B6S	TURNBUCKLE BARREL	1	C,D
-35	MS35338-44	WASHER, LOCK	6	
	ALT: AN935-416			
-36	MS35338-46	WASHER, LOCK	5	
	ALT: AN935-616			
-37	NAS1149F0463P	WASHER, FLAT	6	
	ALT: AN960-416			
-38	NAS1149F0563P	WASHER, FLAT	4	
	ALT: AN960-516			
-39	NAS1149F0663P	WASHER, FLAT	9	
	ALT: AN960-616			
-40	NAS509-5R	NUT, JAM	1	
-41	NAS509-5L	NUT, JAM	1	
-42	M10	WASHER, FLAT, METRIC	2	
-43	10M-1.50	NUT, LOCK, METRIC	1	
-44	10M-1.5x150mm	BOLT, METRIC	1	
-45	AN316-6R	NUT	2	
-46	NAS1149F0632	WASHER, FLAT	4	
	ALT: AN960-616L			
-47	400649-1	I.D. PLATE	1	
NS	Z26-200-8	ADAPTER, B.S.V.	1	
	ALT: Z26-200-8A	ADAPTER, B.S.V.	1	
	..MS28775-013	O-RING	1	
NS	Z26-200-10	ADAPTER, B.S.V.	1	
	ALT: Z26-200-10A	ADAPTER, B.S.V.	1	
	..MS28775-015	O-RING	1	

NOTE 1 Rather assign a unique part number or modification to one-of-a-kind changes for custom applications place an "X" behind the ending dash number. The changes will be identified and recorded with the serial number.



ZEE Systems, Inc.

COMPONENT MAINTENANCE MANUAL Z26-89600

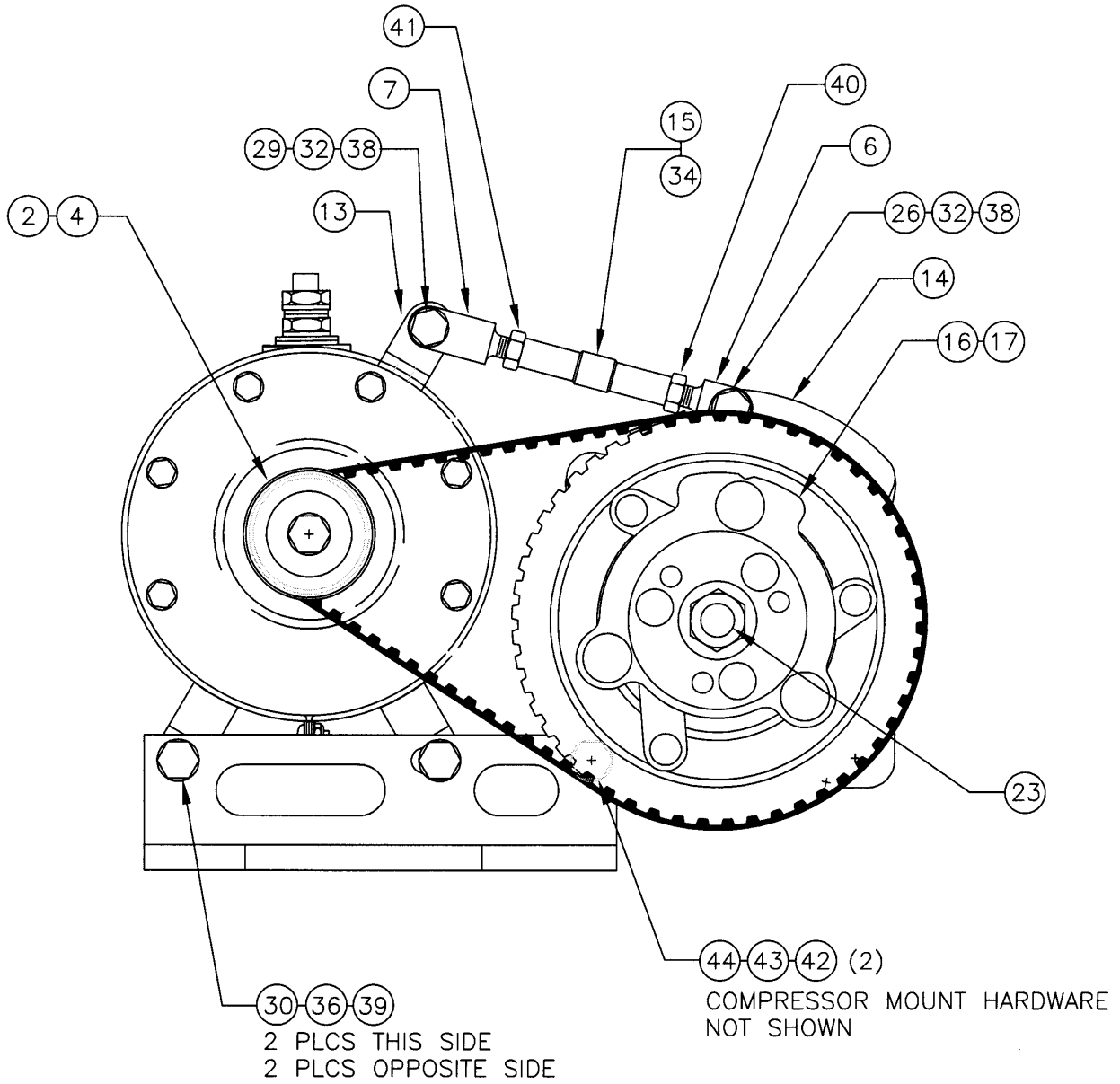

FIG. 2



ZEE Systems, Inc.

COMPONENT MAINTENANCE MANUAL Z26-89600

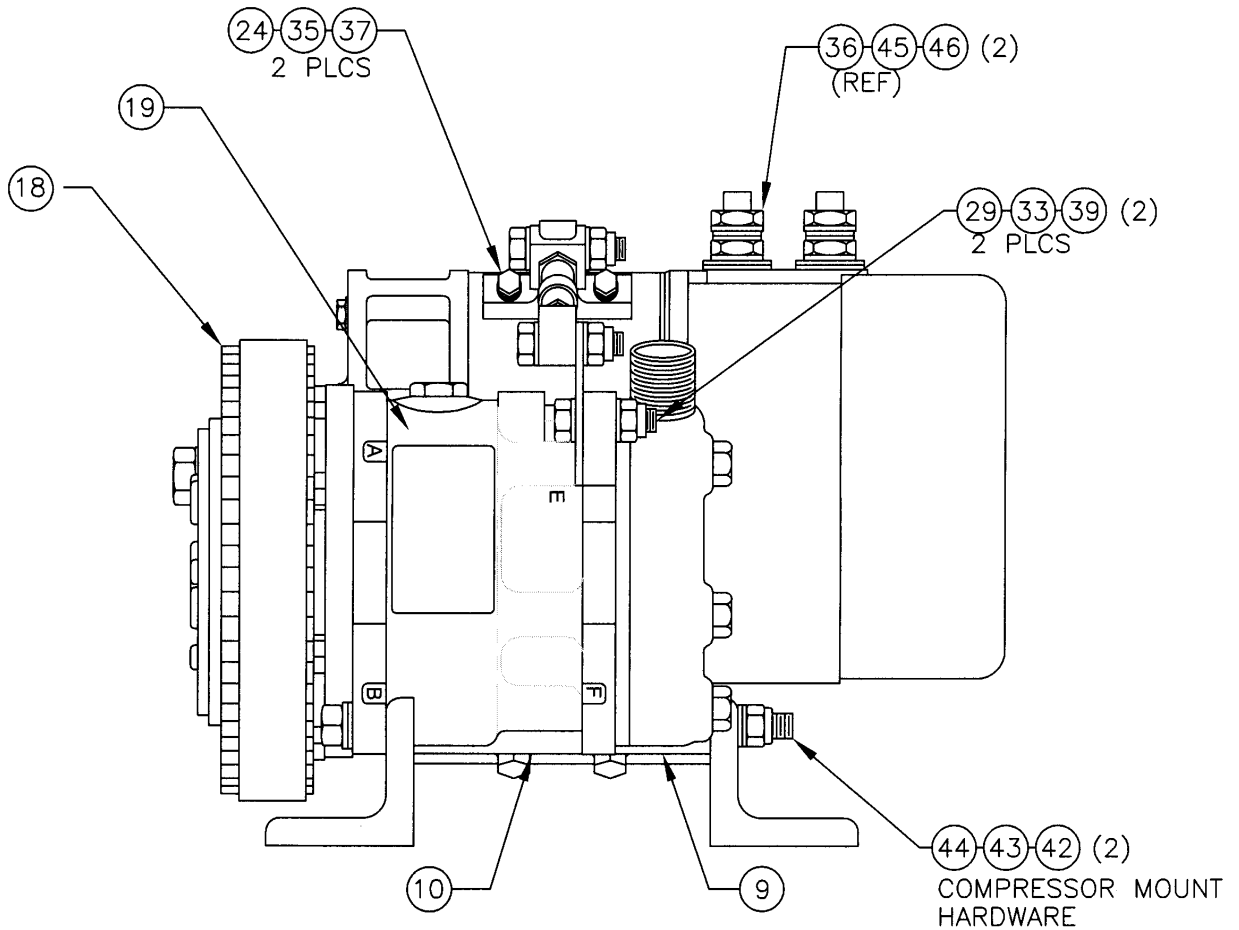

FIG. 3



ZEE Systems, Inc.

COMPONENT MAINTENANCE MANUAL Z26-89600

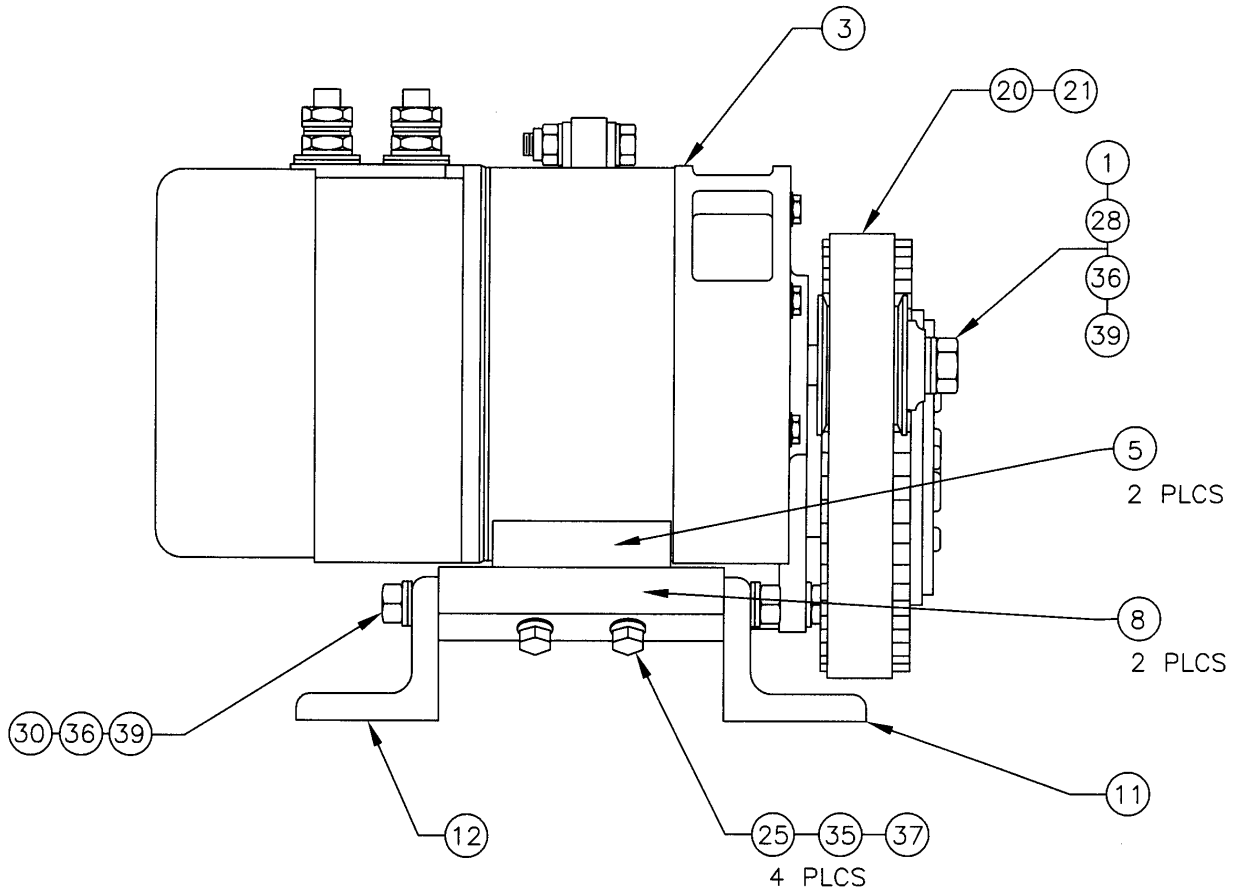

FIG. 4



ZEE Systems, Inc.

COMPONENT MAINTENANCE MANUAL Z26-89600

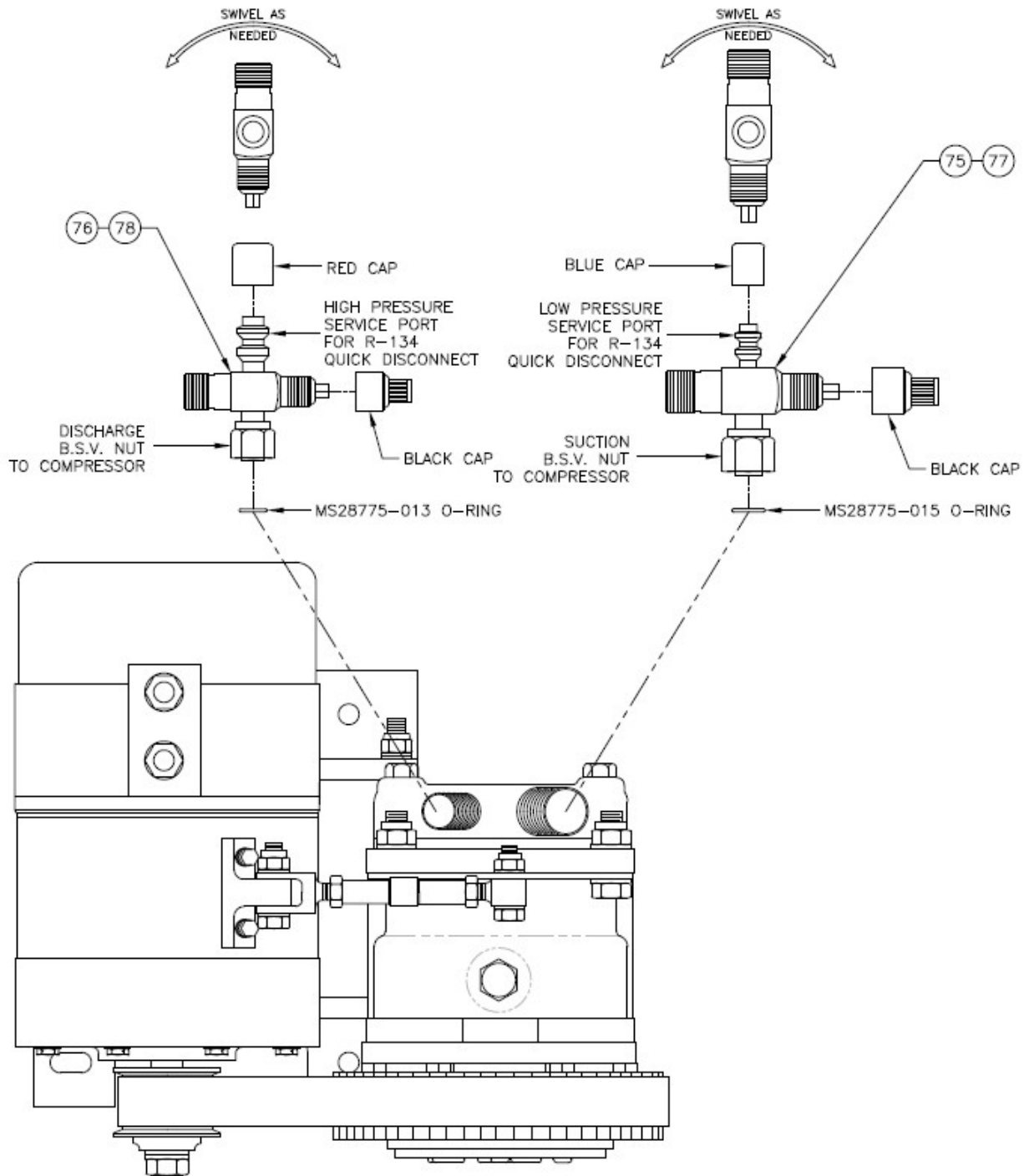

FIG. 5



ZEE Systems, Inc.

COMPONENT MAINTENANCE MANUAL Z26-89600

8.4 ILLUSTRATED PARTS LIST POWER CONDENSER ASSEMBLY.

FIG-ITEM	PART NUMBER	NOMENCLATURE	QTY	USAGE MOD, NOTES CODE
5	Z09-600-3	POWER CONDENSER ASSEMBLY		A
	SZ43-600-1	POWER CONDENSER ASSEMBLY		B
	Z09-600-3 MOD A	POWER CONDENSER ASSEMBLY		C -1 MOD B
	Z14-601-2	POWER CONDENSER ASSEMBLY		D
	SZ43-600-2	POWER CONDENSER ASSEMBLY		E
	Z12-601-2	POWER CONDENSER ASSEMBLY		F
	Z33-601-1	POWER CONDENSER ASSEMBLY		G -2 MOD F
-1	SZ45-029-3A	COVER, TOP	1	A,B,C,D,E,G
	SZ96-305-1	COVER, TOP	1	F
-2	SZ44-030-1B	COIL ASSEMBLY	1	A,B,C,D,E
	SZ96-600-2	COIL ASSEMBLY	1	F
	Z33-600-1	COIL ASSEMBLY	1	G
-3	Z09-300-1	DUCT, OUTLET	1	A
	SZ41-026-1A	DUCT, OUTLET	1	B,E
	Z26-301-1	DUCT, OUTLET	1	C
	SZ41-026-1B	DUCT, OUTLET	1	D
	SZ12-331-2	DUCT, OUTLET	1	F
	Z33-304-1	DUCT, OUTLET	1	G
-4	AN4-6A	BOLT	4	A
-5	MS35338-42	WASHER, LOCK	8	
	ALT: AN935-8			
-6	NAS1149FN816P	WASHER, FLAT	8	
	ALT: AN960-8L			
-7	NAS1149F0432P	WASHER, FLAT	4	
	ALT: AN960-416L			
-8	MS35206-245	SCREW	8	
-9	Z09-602-2	BLOWER MOTOR ASSY	1	A,D NOTE 4
	Z09-602-3	BLOWER MOTOR ASSY	1	B,G NOTE 4
	Z09-601-2	BLOWER MOTOR ASSY	1	C NOTE 4
	Z09-602-4	BLOWER MOTOR ASSY	1	E NOTE 4
	SZ96-801-1	BLOWER MOTOR ASSY	1	F NOTE 4



ZEE Systems, Inc.

COMPONENT MAINTENANCE MANUAL Z26-89600

FIG-ITEM	PART NUMBER	NOMENCLATURE	QTY	USAGE MOD, NOTES CODE	
5	-10	Z14-301-1	DUCT, INLET	1	A,D,E
		SZ43-6301-2	DUCT, INLET	1	B
		Z14-301-2	DUCT, INLET	1	C
		Z12-330-1	DUCT, INLET	1	F
		Z33-303-1	DUCT, INLET	1	G
-11	5/16x7/8	SOCKET HEAD BOLT	4	B,G	
	MS35206-246	SCREW	4	F	
-12	NAS1149F0532P	WASHER, FLAT	4	B,G	
	ALT: AN960-516L				
	MS35338-42	WASHER, LOCK	4	F	
-13	NAS1149FN816P	WASHER, FLAT	4	F	
NS	SZ45-090-1	PLACARD, CAUTION	1		
NS	18-2710	TAPE, INSULATION	AR		
NS	264281-1	I.D. PLATE	1		
NS	403904-1	PLACARD, FLOW	1		
NS	67470	TAPE, FOAM	AR		

NOTE 1 Rather assign a unique part number or modification to one-of-a-kind changes for custom applications place an "X" behind the ending dash number. The changes will be identified and recorded with the serial number.

NOTE 2 MOD F has changed. Was: use of Hose Assembly Z2008210BC236 for any dash no.

NOTE 3 Hose Assemblies which have nickel plated fittings will have an "N" at the end of the part number.

NOTE 4 To order replacement Condenser Fans add an "A" at the end of the basic part number. Replacement fans do not come with the terminal rings. EXAMPLE: For Z09-602-2, order replacement part number Z09-602-2A.



ZEE Systems, Inc.

COMPONENT MAINTENANCE MANUAL Z26-89600

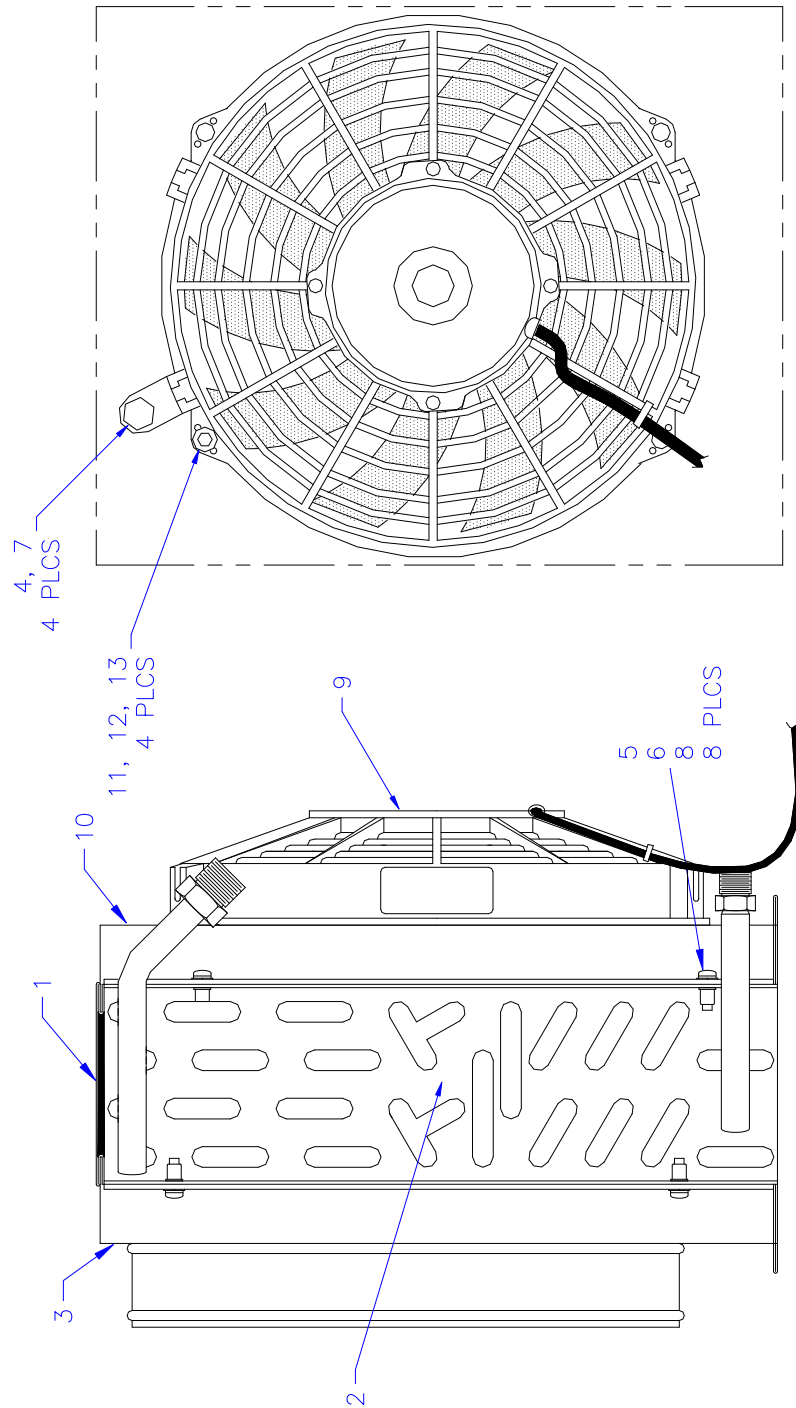

FIG. 6



ZEE Systems, Inc.

COMPONENT MAINTENANCE MANUAL Z26-89600

9.0 SUMMARY OF MODIFICATIONS FOR Z26-89600 MCC

9.1 MOD A. This applies to the Z26-89600-3 Assembly only. When using the Z26-8900-5 (Mod. A Thermal Switch) Motor Compressor Assembly delete the Z031-1-4 Terminal Block and use the Z031-1-6 Terminal Block. Refer to Wiring Diagram 2.

9.2 MOD B. This applies to the Z26-89600-1 Assembly only. Use the Z09-600-3 MOD A Power Condenser Assembly.

9.3 MOD C. This applies to the Z26-89600-1/-2/-3/-4 Assemblies only using Hose Assembly Z2008210BC313.

9.4 MOD D Allows for using the Z26-8900-7 MC. Factory modification only.

9.5 MOD E This applies to all dash numbers using Hose Assembly Z2018210BC313.

9.6 MOD F This applies to Z26-89600-2 only. Use the Z33-601-1 Power Condenser Assembly. Use Hose Assembly Z2008175CD162. SEE NOTE 2 below.

9.7 MOD G Applicable to Z26-89600-2 only. Use Z26-8900-1 with MOD J. Add SZ43-304-1A Base Plate and Z2008175CD182 Hose Assy.

9.8 MOD H Applicable to Z26-89600-2 only. Use Z26-8900-1 with MOD K.

9.9 MOD I NOT USED.

9.10 MOD J Applicable to Z26-89600-2 with MOD F only. Add Hose Assembly Z2008165BC313. Delete Z2008175CD182 and Z200175CD162.

9.11 MOD K Applicable to Z26-89600-2 with MOD F only. Add Hose Assembly Z2008090BC300. See SERVICE LETTER SL Z26-89600-3, Rev. 1.

NOTE 1 Rather assign a unique part number or modification to one-of-a-kind changes for custom applications place an "X" behind the ending dash number. The changes will be identified and recorded with the serial number.

NOTE 2 MOD F has changed. Was: use of Hose Assembly Z2008210BC236 for any dash no.

NOTE 3 Hose Assemblies which have nickel plated fittings will have an "N" at the end of the part number.

NOTE 4 Applies to Z26-89600-2 with MOD F only.

NOTE 5 Applies to Z26-89600-2 with MOD F only. Delete all previous hose assemblies, Z2008AB83, Z2008175CD162, Z2008210BC313, Z2008175CD182. See SERVICE LETTER SL Z26-89600-3, Rev. 1.